

CATALOG cylinders

Tiny Titan Series

Small Bore, Square End Cap Cylinder Line



NUMATICS

<i>Tiny Titan Series</i>	3-22
Features and Benefits	3
How to Order	4
Optional Features	5
Basic and Front Flange Mounts	6
Front and Rear Flange Mounts	7
Nose Mounts	8
Fixed Eye and Front Tap Mounts	9
Side and Bottom Mount	10
Accessories	11
Rod Ends and Accessories	12
Global Switches	13-14
World Switches	15-16
How to Order - Tiny Titan Series Piston Rod Assembly	17
How to Order - Tiny Titan Series Repair Kit	18
How to Order - Tiny Titan Series Seal Kit	18
Piston Rod Assembly Kit Removal/Installation Instructions	19
Diagrams	20
Repair Kit Removal/Installation Instructions	21
Seal Kit Removal/Installation Instructions	22



The **Tiny Titan Series** is a small bore, square end cap cylinder line that is designed to excel in applications where space limitations are of the utmost importance. Furthermore, a multitude of mounting styles and piston options make the Tiny Titan an extremely accommodating cylinder line.

Tube

The **tube** is hard coat anodized on the inner diameter. This surface is extremely hard and possesses excellent wear and corrosion resistance, and has a low coefficient of friction. Additionally, profile tubing is standard on all bore sizes.

End Caps

The **end caps** are accurately machined from (6061-T6) solid aluminum bar stock. They are anodized for corrosion resistance. Additionally, a recess on the piston-mating surface (at both ends) enables the air to work on a larger piston area for effortless breakaway.

Rod Seal and Wiper

The unique **rod seal** and **wiper** combination is standard. The quad ring design ensures proper sealing and long life.

Tube End Seal

The **tube end seals** are compression type and reusable.

Ports

Our enhanced **port** design enables the cylinder to work more efficiently. Through the use of precise machining depths and tool shape, we are able to smooth the flow path into and out of the cylinder.

The The Tiny Titan Series **piston, piston rod, rod bushing, wear band, and rod seal** is directly correlated to the three different types of pistons that are offered: O Type, P Type, and Q Type.

O Type Piston

The **O Type piston** (standard) is designed with a U-cup (Block-V) piston seal, a sintered bronze rod bushing, a roller burnished type 303 stainless steel piston rod, and a solid aluminum alloy piston that is strong and durable.

P Type Piston

The **P Type piston** is a heavy-duty design. The piston seal is carboxylated nitrile with Teflon® compound for self-lubrication. The "T" seal with back-up ring construction prevents rolling and seals at all pressures. Furthermore, this design includes a robust cast iron rod bushing, a high strength chrome plated carbon steel piston rod, a wear band, and a solid aluminum alloy piston that is strong and durable.

Q Type Piston

The **Q Type piston** is a low profile design. The piston seal is a carboxylated nitrile with Teflon® compound for self-lubricating. The "T" seal with back-up ring construction prevents rolling and seals at all pressures. It also has sintered bronze rod bushing, a roller burnished type 303 stainless steel piston rod, and a solid aluminum alloy piston that is strong and durable. A magnet cannot be added to the Q Type piston. Furthermore, a minimum of .625" of stroke is required.

Teflon® is a registered trademark of DuPont™.

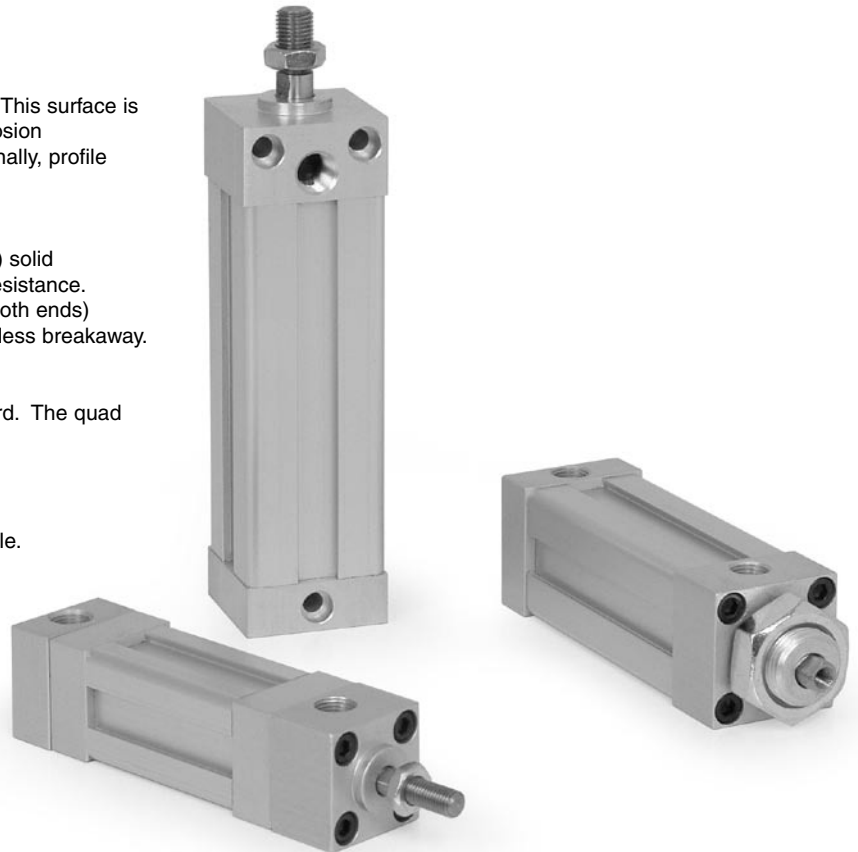

Standard Specifications:

- Bore sizes include 3/4", 1", 1-1/8"
- Nominal pressure rating is 150 psi air
- Standard temperature -10°F to 165°F (-23°C to 74°C)
- All aluminum construction
- 1/8" ports
- Flexible port locations
- O Type piston - U-cup
- P Type piston – heavy-duty (Standard)
- Q Type piston – low profile



Tiny Titan Series Small Bore, Square Cylinder

NUMATICS®

How to Order

S8 0 C - 04 A 1 B - A AA 0

Mount

- F1 = Front Flange (Pilot)
- F2 = Rear Flange
- F7 = Front Flange
- N1 = Nose Mount
- N2 = Nose Mount (Pilot)
- P3 = Rear Eye Mount
- R1 = Sleeve Nut Mount
- S8** = Through Holes
- S9** = Bottom Tapped
- X0 = No Mount

Cylinder Type

- O = U-Cup Piston
- P = Heavy Duty Piston
- Q* = Low Profile Piston

Bore

- C = 3/4"
- E = 1"
- G = 1-1/8"

Full Inches of Stroke

- 00 = 0" Stroke
- 01 = 1" Stroke
- 02 = 2" Stroke
- 03 = 3" Stroke
- 10" = 10" Stroke

Fractional Inches of Stroke

- | | |
|-----------|------------|
| A = 0" | I = 1/2" |
| B = 1/16" | J = 9/16" |
| C = 1/8" | K = 5/8" |
| D = 3/16" | L = 11/16" |
| E = 1/4" | M = 3/4" |
| F = 5/16" | N = 13/16" |
| G = 3/8" | O = 7/8" |
| H = 7/16" | P = 15/16" |

Magnetic Piston

- 0 = No Magnet
 - 2 = Magnet
- Magnet not available on Q Type piston.

Options

- AA = No Options
- EB* = Bumper Seal, Both Ends
- KA = Stroke Adjuster (1" Max. Adjustment)
- NA = Nickel Plated
- VA = Viton Seals
- 1A** = Rod Extension
- 2A** = Thread Extension
- 4A** = Stop Tube

*Requires a minimum of 100 psi for the rod to reach the full end of stroke with the EB option. EB option is not available on Q Type piston.

Cushions (1/2" Added Per End)

Position	1	2	3	4
No Cushion	A	A	A	A
Head and Cap	B	C	D	E
Head Only	F	G	H	J
Cap Only	K	L	M	N

NOTE: P type cap cushion not available.

** Must specify length.

Ports

Position	
1 (Std.)	B = 1/8 NPTF
2	H = 1/8 NPTF
3	N = 1/8 NPTF
4	T = 1/8 NPTF

Rod End Code

- 1 = #1 Standard Rod Diameter
- 2 = #2 Standard Rod Diameter
- 3 = #3 Standard Rod Diameter
- 6 = #1 Oversize Rod Diameter
- 7 = #2 Oversize Rod Diameter
- 8 = #3 Oversize Rod Diameter

Cylinder Orientation

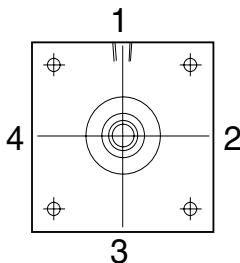

Ports Normally in Position 1

Cylinder Forces

Force Chart

Pressure (PSI)

BORE	40	60	80	100	125	150	
3/4"	Extend	17	26	35	44	55	66
	Retract (Std. Rod)	15	23	31	39	49	58
	Retract (Ov. Rod)	14	21	29	36	45	54
1"	Extend	31	47	62	78	98	117
	Retract (Std. Rod)	28	42	56	70	88	106
	Retract (Ov. Rod)	27	40	54	67	84	101
1 1/8"	Extend	39	59	79	99	124	149
	Retract (Std. Rod)	35	53	70	88	110	132
	Retract (Ov. Rod)	31	47	63	79	99	119



Optional Features

O Type Piston (Standard)

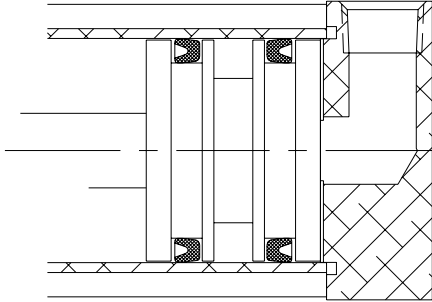

- U-cup (Block-V) piston seals
- Low breakaway
- Groove for optional magnet

O Type Cap Cushion

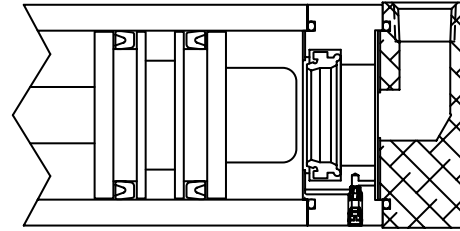

- The cushion seal has a built in check function. It seals in one direction and permits full flow in the opposite direction.
- Captured cushion needle
- Length grows by 1/2" per end

P Type Piston

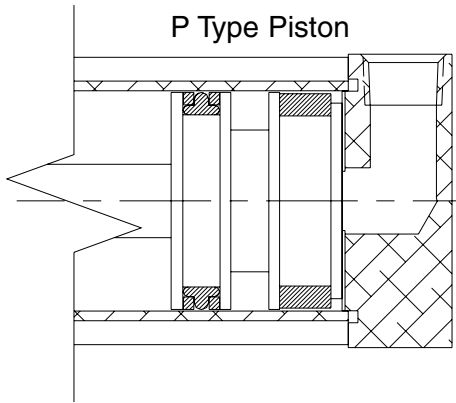

- Heavy duty
- Non-lube service
- T style piston seal
- Wear band
- Groove for optional magnet

Silencer Bumper Seal

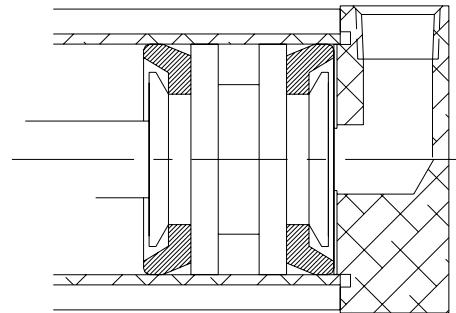

- Reduces end of stroke impact noise
- Bumper seal does not change cylinder overall length
- Cushions not available with this option
- Requires a minimum of 100 psi for the rod to reach the full end of stroke with the EB option.

Q Type Piston

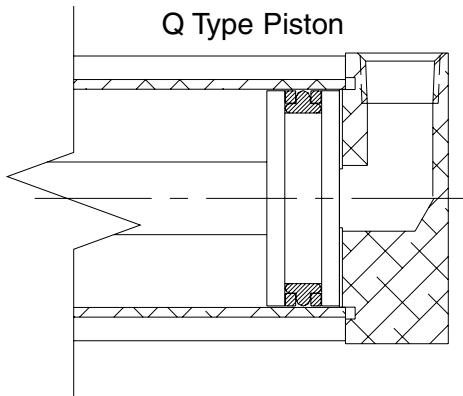

- Low profile design
- T style piston seal

Stroke Adjust

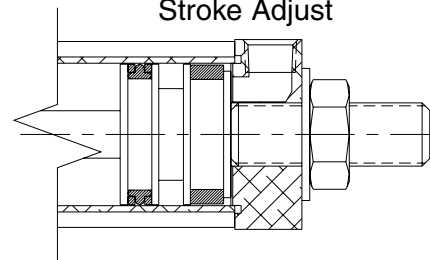

BORE	JA	JB	JC
3/4"	3/8-24	1.44	3/16
1" and 1-1/8"	1/2-20	1.44	1/4

- 1" maximum adjustment



Tiny Titan Series Small Bore, Square Cylinder

NUMATICS®

Basic and Front Flange Mounts

Mount Code X0 (Basic No Mount)

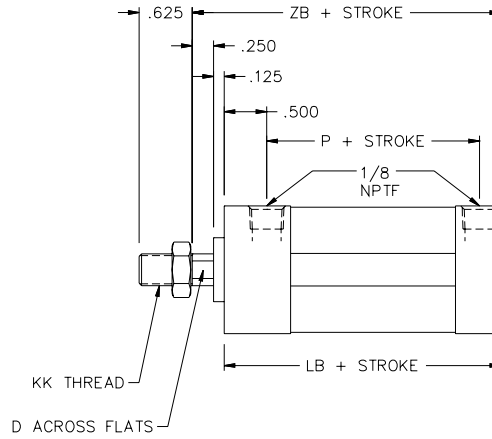
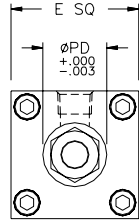

Mount Code F1 (Front Flange Mount with Pilot)

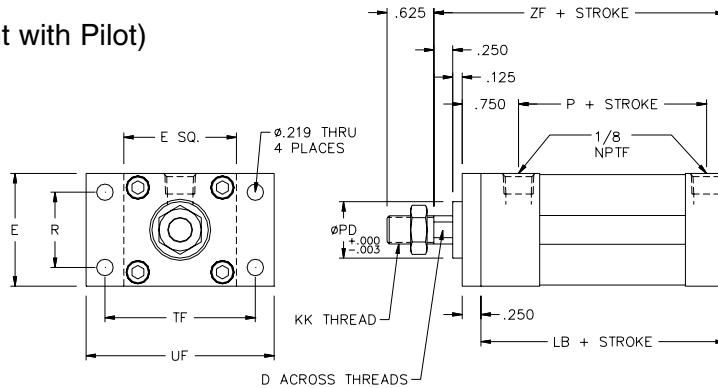

Dimensions

BORE	E	D	PD	KK**	R	TF	UF
3/4"	1.125	0.188	0.625	1/4-28	0.500	1.500	2.000
1"	1.375	0.250	0.750	5/16-24	0.875	1.875	2.375
1 1/8"	1.500	0.313	0.750	3/8-24	1.000	2.000	2.500

Stroke Related Dimensions

SERIES	O and P*				Q*			
	BORE	LB	P	ZB	ZF	LB	P	ZB
3/4"	2.250	1.500	2.625	2.875	1.750	1.000	2.125	2.375
1"	2.250	1.500	2.625	2.875	1.750	1.000	2.125	2.375
1 1/8"	2.250	1.500	2.625	2.875	1.750	1.000	2.125	2.375

* Cushions: Adds 1/2" per end to the OAL of the cylinder.

** Rod Ends: See page 12 for rod end options.



Front and Rear Flange Mounts

Mount Code F2 (Rear Flange Mount)

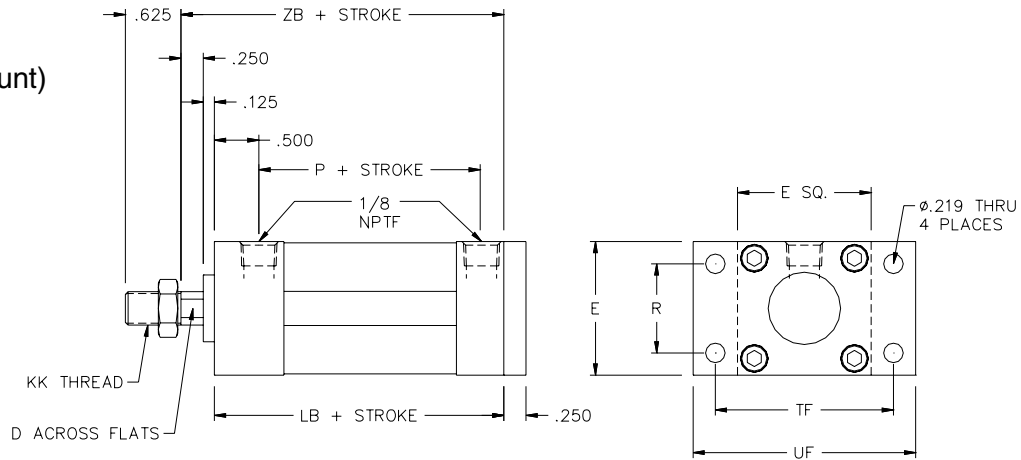

Mount Code F7 (Front Flange Mount)

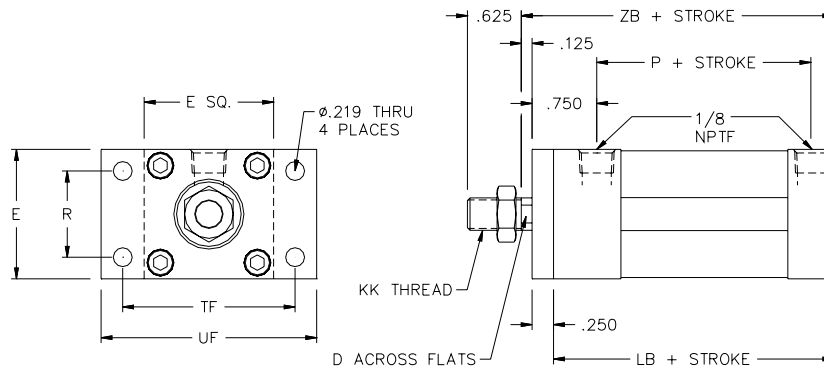

Dimensions

BORE	E	D	KK**	R	TF	UF
3/4"	1.125	0.188	1/4-28	0.500	1.500	2.000
1"	1.375	0.250	5/16-24	0.875	1.875	2.375
1 1/8"	1.500	0.313	3/8-24	1.000	2.000	2.500

Stroke Related Dimensions

SERIES	O and P*			Q*		
BORE	LB	P	ZB	LB	P	ZB
3/4"	2.250	1.500	2.625	1.750	1.000	2.125
1"	2.250	1.500	2.625	1.750	1.000	2.125
1 1/8"	2.250	1.500	2.625	1.750	1.000	2.125

* Cushions: Adds 1/2" per end to the OAL of the cylinder.

** Rod Ends: See page 12 for rod end options.



Tiny Titan Series Small Bore, Square Cylinder

NUMATICS®

Nose Mounts

Mount Code N1 (Nose Mount)

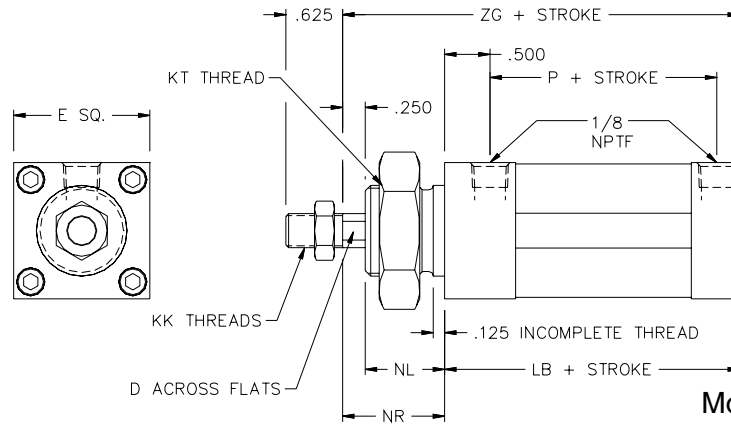

Mounting Nuts Included

Mount Code N2 (Nose Mount with Pilot)

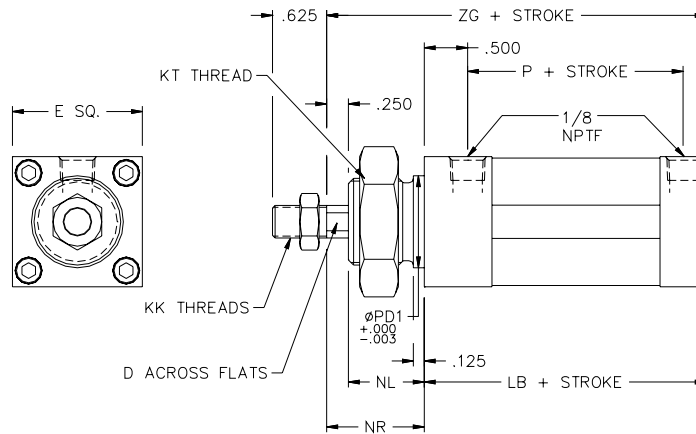

Mounting Nuts Included

Dimensions

BORE	E	D	PD1	KK**	KT	NL	NR
3/4"	1.125	0.188	0.687	1/4-28	5/8-18	0.625	0.875
1"	1.375	0.250	0.812	5/16-24	3/4-16	0.625	0.875
1 1/8"	1.500	0.313	1.062	3/8-24	1-14	0.875	1.125

Stroke Related Dimensions

SERIES	O and P*			Q*			
	LB	P	ZG	LB	P	ZG	
3/4"	2.250	1.500	3.125	1.750	1.000	2.625	
1"	2.250	1.500	3.125	1.750	1.000	2.625	
1 1/8"	2.250	1.500	3.125	1.750	1.000	2.875	

* Cushions: Adds 1/2" per end to the OAL of the cylinder.

** Rod Ends: See page 12 for rod end options.



Fixed Eye and Front Tap Mounts

Mount Code P3 (Eye Mount)

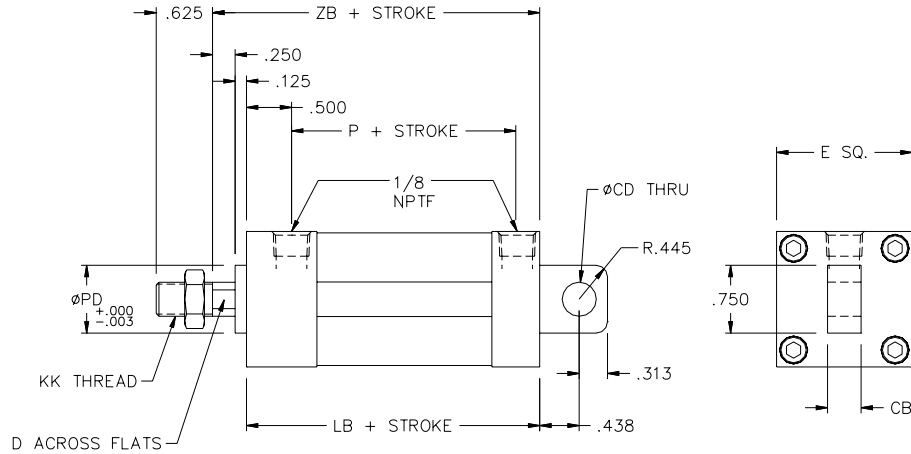

Mount Code R1 (Front Tapped Mount)

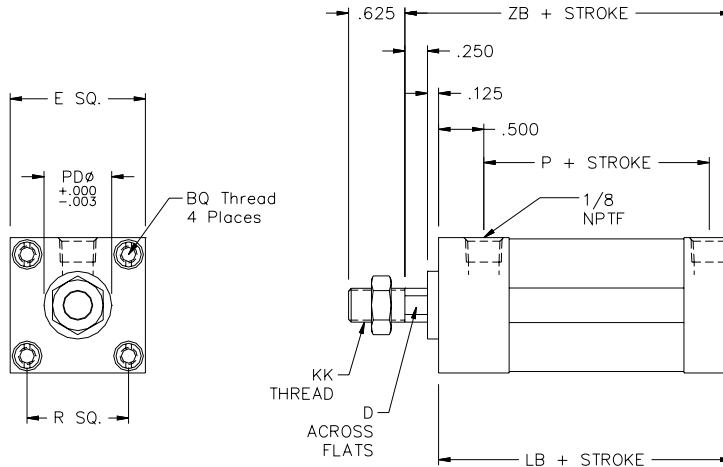

Dimensions

BORE	E	BQ	CB	CD	D	KK**	PD	R
3/4"	1.125	8-32 X 1/4 DEEP	0.250	0.250	0.188	1/4-28	0.625	0.750
1"	1.375	8-32 X 1/4 DEEP	0.375	0.375	0.250	5/16-24	0.750	1.000
1 1/8"	1.500	10-32 X 1/4 DEEP	0.375	0.375	0.313	3/8-24	0.750	1.125

Stroke Related Dimensions

SERIES BORE	O and P*			Q*		
	LB	P	ZB	LB	P	ZB
3/4"	2.250	1.500	2.625	1.750	1.000	2.125
1"	2.250	1.500	2.625	1.750	1.000	2.125
1 1/8"	2.250	1.500	2.625	1.750	1.000	2.125

* Cushions: Adds 1/2" per end to the OAL of the cylinder.

** Rod Ends: See page 12 for rod end options.



Tiny Titan Series Small Bore, Square Cylinder

NUMATICS®

Side and Bottom Mount

**Mount Code S8
(Side Mount)**
Standard ports in
position # 1. Consult
factory for details.

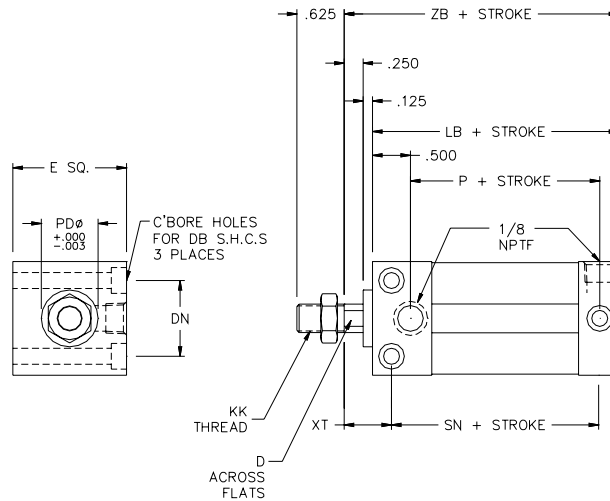

**Mount Code S9
(Bottom Tapped Mount)**
Standard ports in
position # 1. Consult
factory for details.

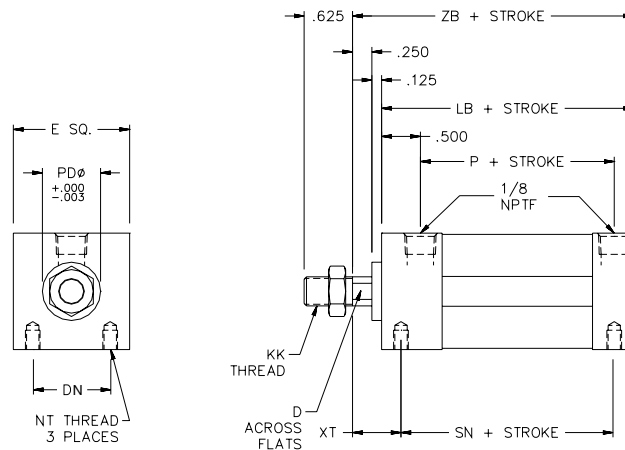

Dimensions

BORE	E	D	DB	DN	PD	KK**	NT	XT
3/4"	1.125	0.188	#8	0.625	0.625	1/4-28	8-32 X .18 DEEP	0.563
1"	1.375	0.250	#10	0.875	0.750	5/16-24	10-32 X .25 DEEP	0.625
1 1/8"	1.500	0.313	#10	1.000	0.750	3/8-24	10-32 X .25 DEEP	0.625

Stroke Related Dimensions

SERIES	O and P*				Q*				
	BORE	LB	P	SN	ZB	LB	P	SN	ZB
3/4"		2.250	1.500	1.812	2.625	1.750	1.000	1.312	2.125
1"		2.250	1.500	1.750	2.625	1.750	1.000	1.250	2.125
1 1/8"		2.250	1.500	1.750	2.625	1.750	1.000	1.250	2.125

* Cushions: Adds 1/2" per end to the OAL of the cylinder.

** Rod Ends: See page 12 for rod end options.



Accessories

Rod Eye

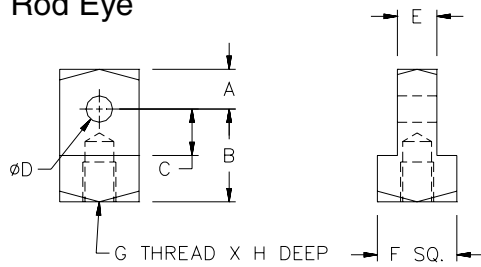

PART #*	A	B	C	D	E	F	G	H
P26-C01	0.250	0.750	0.438	0.250	0.250	0.500	1/4-28	0.280
P26-E01	0.375	0.875	0.438	0.375	0.375	0.750	5/16-24	0.380
P26-E02	0.375	0.875	0.438	0.250	0.375	0.750	5/16-24	0.380
P26-G01	0.375	0.875	0.438	0.375	0.375	0.750	3/8-24	0.310
P26-G02	0.375	0.875	0.438	0.250	0.375	0.750	3/8-24	0.310

* Parts are zinc plated steel

Rod Clevis (Pivot Pin Included)

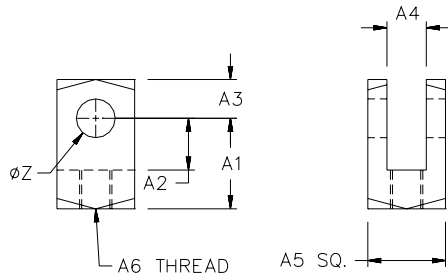

PART #*	Z	A1	A2	A3	A4	A5	A6
P500-301	0.250	0.812	0.500	0.250	0.250	0.500	1/4-28
P500-302	0.375	0.875	0.500	0.375	0.375	0.750	5/16-24
P500-303	0.250	0.875	0.500	0.375	0.375	0.750	5/16-24
P500-304	0.375	0.875	0.500	0.375	0.375	0.750	3/8-24
P500-305	0.250	0.875	0.500	0.375	0.375	0.750	3/8-24

* Parts are zinc plated steel

Clevis Bracket (Pivot Pin Included)

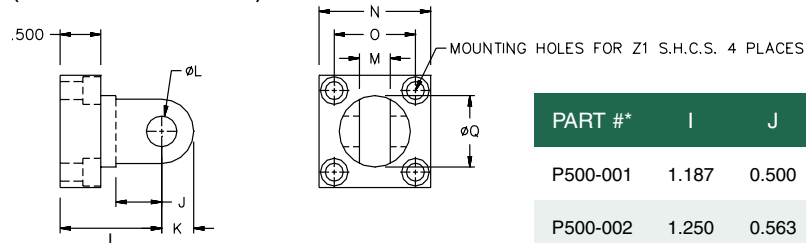

PART #*	I	J	K	L	M	N	O	Q	Z1
P500-001	1.187	0.500	0.250	0.250	0.250	1.125	0.750	0.750	#6
P500-002	1.250	0.563	0.375	0.375	0.375	1.375	1.000	0.875	#10
P500-003	1.250	0.563	0.375	0.250	0.375	1.375	1.000	0.875	#10

* Parts are zinc plated steel

Eye Bracket

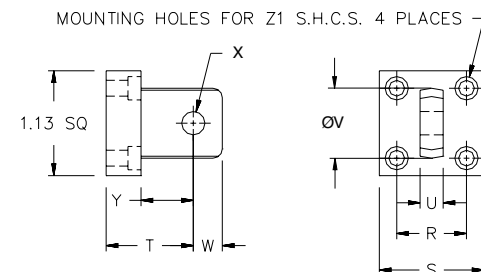

PART #*	R	S	T	U	V	W	X	Y	Z1
P30-C01	0.75	1.125	0.937	0.250	0.750	0.312	0.250	0.56	#6
P30-E01	1.000	1.375	0.937	0.375	0.750	0.312	0.375	0.56	#10
P30-E02	1.000	1.375	0.937	0.375	0.750	0.312	0.250	0.56	#10

* Parts are zinc plated steel



Tiny Titan Series Small Bore, Square Cylinder

Rod Ends and Accessories

Rod Ends

Styles 1 and 2

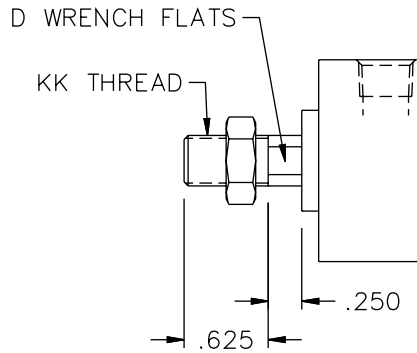

Style 3

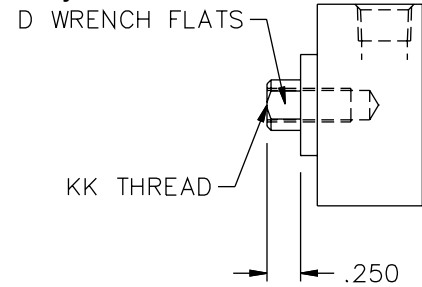

Jam nuts included with Style 1 and Style 2 rod ends.

BORE	ROD	STYLE 1	STYLE 2	STYLE 3	D
3/4"	0.250	1/4-28	1/4-20	6-32 X .44 DEEP	0.188
3/4"	0.312	5/16-24	5/16-18	10-32 X .63 DEEP	0.250
1"	0.312	5/16-24	5/16-18	10-32 X .63 DEEP	0.250
1"	0.375	3/8-24	3/8-16	1/4-28 X .63 DEEP	0.312
1 1/8"	0.375	3/8-24	3/8-16	1/4-28 X .63 DEEP	0.312
1 1/8"	0.500	1/2-20	1/2-13	3/8-24 X .63 DEEP	0.438

Rod Couplers

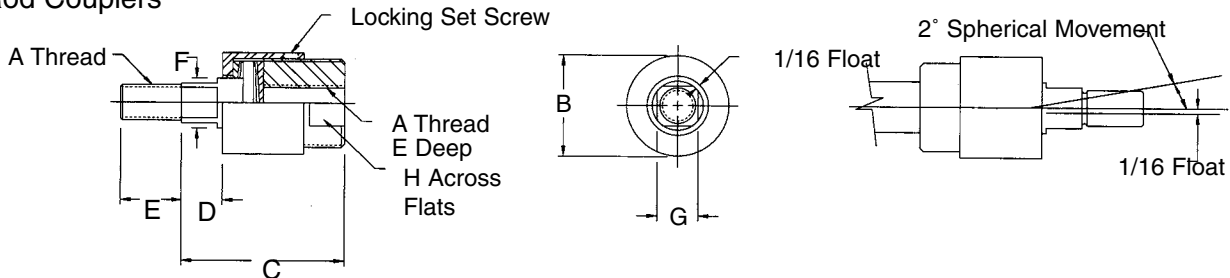

PART #	A	B	C	D	E	F	G	H
A500-600	1/4-28	7/8	1-1/4	1/4	5/8	5/16	3/16	3/4
A500-601	5/16-24	7/8	1-1/4	1/4	5/8	5/16	1/4	3/4
A500-602	3/8-24	7/8	1-1/4	1/4	5/8	5/16	5/16	3/4
A500-604	1/2-20	1-1/4	2	1/2	3/4	5/8	1/2	1

Pivot Pin

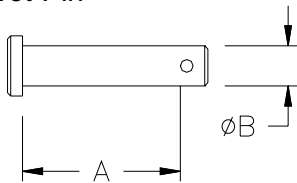

PART #*	A	B
P500-401	0.984	0.250
P500-403	0.891	0.375

* Parts are zinc plated steel

Hex Nuts

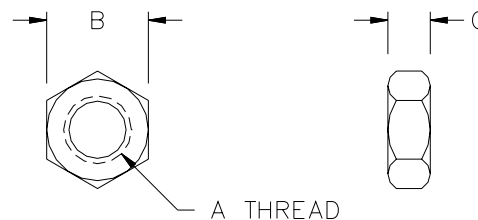

PART#*	A	B	C
N90-1093	1/4-20	0.44	0.16
M190001	1/4-28	0.44	0.16
N90-1094	5/16-18	0.50	0.19
M18-004	5/16-24	0.50	0.19
N90-1062	3/8-16	0.56	0.22
M190002	3/8-24	0.56	0.22
N90-1095	1/2-13	0.75	0.31
M190004	1/2-20	0.75	0.31
M190005	5/8-18	0.94	0.38
M190006	3/4-16	1.12	0.42
M190008	1-14	1.50	0.55

* Parts are zinc plated steel



P series Global application Detail

Profile Tube Detail

1. Global Switch
2. Included Dovetail adapter
3. Dove Tail extrusion

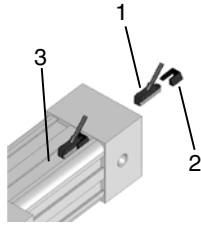

Tiny Titan Series World Switch Bracket

Cylinders	Bore	Part Number
Tiny Titan series	All	Direct Fit

Tiny Titan Series World Switch Hall Effect Part Numbers

P/N	Switch Style	Switch Type	Function	Switching Voltage	Switching Current	Switching Power	Voltage Drop
SH6-031	3m Wire Version	Hall Effect for Reed Magnet & Light Sourcing	Normally Open Sourcing (PNP)	6 -24 VDC	0.3 Amps Max.	7.2 Watts Max.	0.5 Volts
SH6-021	8m Connector Pigtail	Hall Effect for Reed Magnet & Light Sourcing	Normally Open Sourcing (PNP)	6 -24 VDC	0.3 Amps Max.	7.2 Watts Max.	0.5 Volts
SH6-032	3m Wire Version	Hall Effect for Reed Magnet & Light Sourcing	Normally Open Sourcing (NPN)	6 -24 VDC	0.3 Amps Max.	7.2 Watts Max.	0.5 Volts
SH6-022	8m Connector Pigtail	Hall Effect for Reed Magnet & Light Sourcing	Normally Open Sourcing (NPN)	6 -24 VDC	0.3 Amps Max.	7.2 Watts Max.	0.5 Volts

Hall Effect Switch

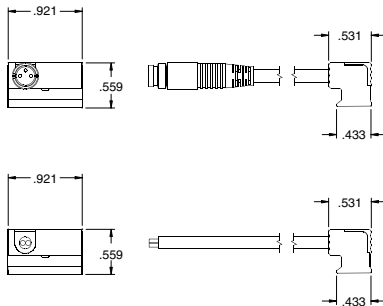

PNP Sourcing

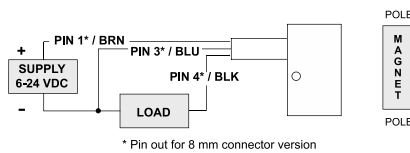

NPN Sinking

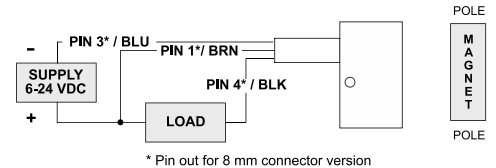



Tiny Titan Series Small Bore, Square Cylinder

NUMATICS®

A Series World Switch Reed Switch Part Numbers

P/N	Switch Style	Switch Type	Function	Switching Voltage	Switching Current	Switching Power	Voltage Drop
SR6-002	3m Wire Version	Reed Switch, LED	SPST Normally Open	5 - 120V AC/DC	0.025 Amps Max. 0.001 Amps Min.	3 Watts Max.	3.5 Volts
SR6-004	3m Wire Version	Reed Switch, LED & MOV	SPST Normally Open	5 - 120V AC/DC	0.5 Amps Max. 0.005 Amps Min.	10 Watts Max.	3.0 Volts
SR6-021	8mm Pigtail	Reed Switch	SPST Normally Open	0 - 120V AC/DC	0.5 Amps Max.	10 Watts Max.	0 Volts
SR6-022	8mm Pigtail	Reed Switch, LED	SPST Normally Open	5 - 120V AC/DC	0.025 Amps Max. 0.001 Amps Min.	3 Watts Max.	3.5 Volts
SR6-024	8mm Pigtail	Reed Switch, LED & MOV	SPST Normally Open	5 - 120V AC/DC	0.5 Amps Max. 0.005 Amps Min.	10 Watts Max.	3.0 Volts

Reed Switch - Normally Open Type SR6

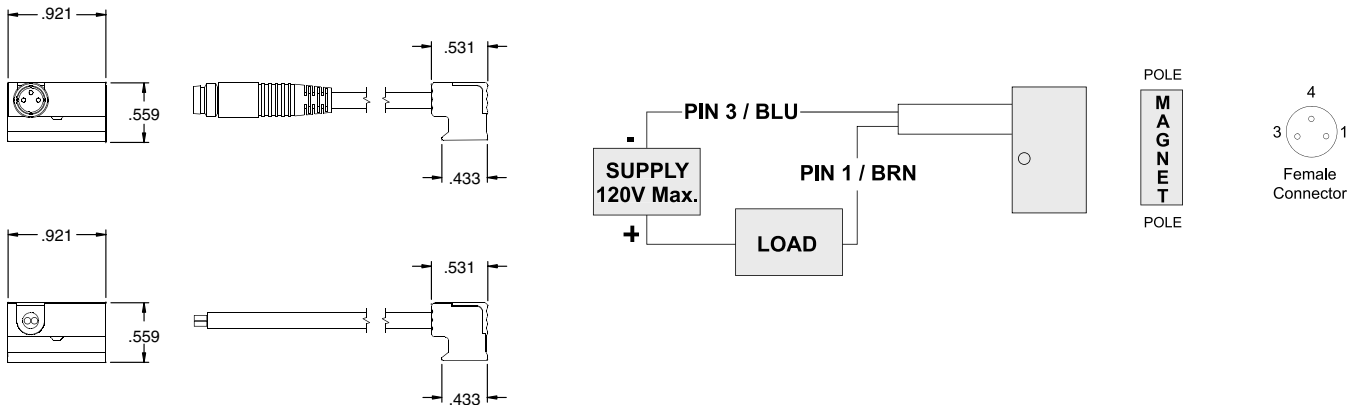

Cords M8-thread for Switches and Sensors with Connector

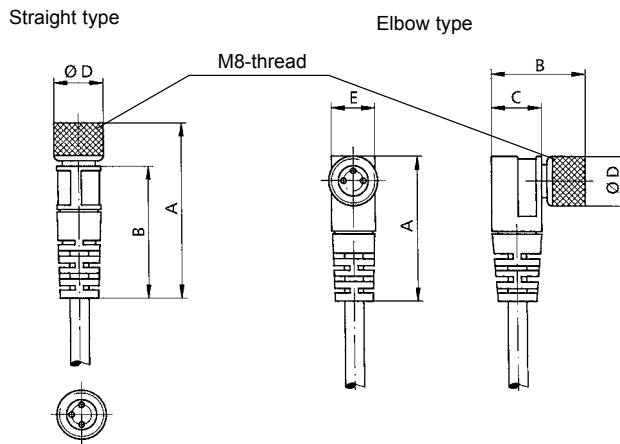

Dimensions (mm)

Type		A	B	C	D	E	Weight (approx. kg)	Order Code
Straight with 5m-cable	(3x0.25 mm ²)	32.3	24.4	—	9.0	—	0.143	SC6-001
Elbow with 5m-cable	(3x0.25 mm ²)	26.3	17.1	9.2	9.0	8.0	0.145	SC6-002



P series World application Detail

Profile Tube Detail

1. World Switch
2. Dove Tail extrusion

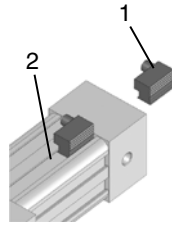

Tiny Titan Series Global Switch Bracket

Cylinders	Bore	Part Number
Tiny Titan series	All	Direct Fit w/included adapter

Tiny Titan Series Global Switches

Reed Switch (AC/DC NO), flying lead - RSS02, 8mm connector - RSQ02

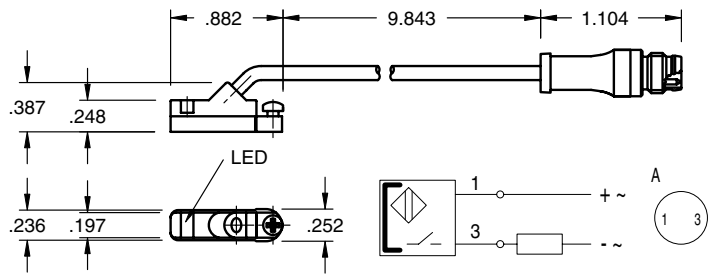
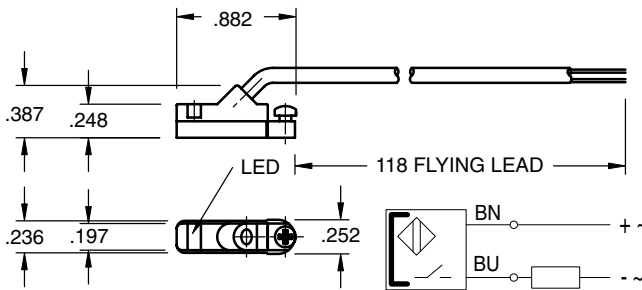

Sensing Data

Ambient temperature range T_a	(°F/°C)	-4 to 176 (-20 to 80)
Frequency of operating cycles f at U_e	(kHz)	0.5
Turn on time t	(ms)	≤ 0.25
Turn off time t	(ms)	0.03
LED function indication		yes

Electrical Data

Rated operational voltage U_e	(V)	3...130 AC/DC
Supply voltage U_B	(V)	3...130 AC/DC
Voltage drop U_d at I_e Stat./dyn.	(V)	3.5
Rated insulation voltage U_i	(V)	2750 DC (EN 60335-1)
Rated supply frequency	(Hz)	AC/DC
Rated operational current I_e	(mA)	50 (10W max.)
No-load supply current I_0 at U_e d./und.	(mA)	0

Observe polarity for correct LED function

Mechanical Data

Housing material	Polyamide
Material of sensing face	Polyamide
Connection	PVC cable
Degree of Protection	IP 67
Rated shock: half-sinus, 50g, 11 ms	
Rated vibration environment: 10g, 10...2000 Hz, 90 min	





Tiny Titan Series Small Bore, Square Cylinder

NUMATICS®

Electronic Switch (PNP NO), flying lead - HPNPS31, 8mm connector - HPNPQ31

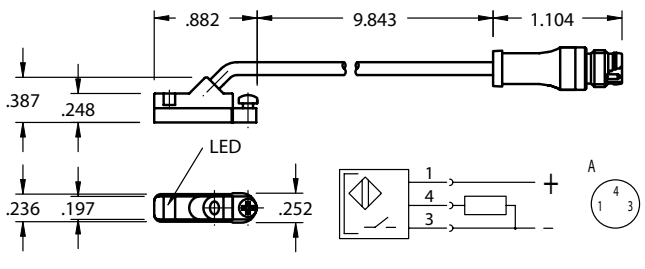
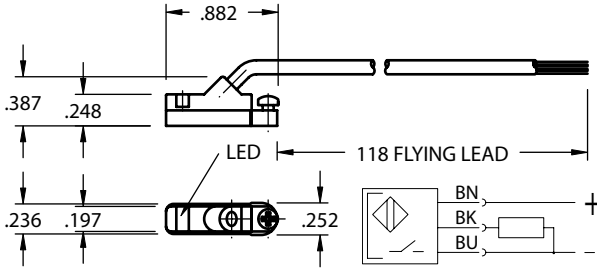

Sensing Data

Ambient temperature range θ_d	(°F/°C)	-13 to +158 (-25 to +70)
Temperature drift	(% of)	$\leq 0.3\%/^{\circ}\text{C}$
Frequency of operating cycles f at U_e	(kHz)	10
Turn on time t	(ms)	.05
turn off time t	(ms)	.05
Utilization categories		DC13
Function-/supply voltage indication		YES

Mechanical Data

Housing material	Polyamide
Material of sensing face	Polyamide
Connection	PVC cable
Degree of Protection	IP 67
Rated shock: half-sinus, 30 g, 11 ms	
Rated vibration environment: 55 Hz, 1mm amplitude, 3 x 30	

Electrical Data

Rated operational voltage U_e	(V)	24 DC
Supply voltage U_B	(V)	10...30 DC
incl. ripple	(% of U_e)	15
Voltage drop U_d at I_e Stat./dyn.	(V)	1/-
Rated insulation volatage U_i	(V)	75 AC
Rated supply frequency	(Hz)	DC
Rated operational current I_e	(mA)	200
No-load supply current I_o at U_e d./und.	(mA)	25/13
Protected against polarity reversal		YES



Electronic Switch (NPN NO), flying lead - HNPNS32, 8mm connector - HNPNQ32

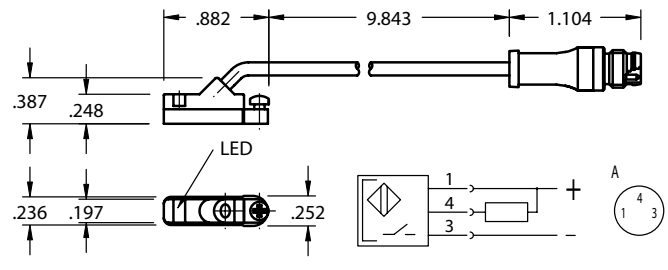
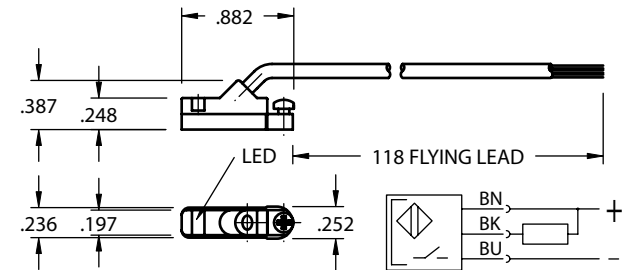

Sensing Data

Ambient temperature range θ_d	(°F/°C)	-13 to +158 (-25 to +70)
Temperature drift	(% of S_T)	$\leq 0.3\%/^{\circ}\text{C}$
Frequency of operating cycles f at U_e	(kHz)	10
Turn on time t	(ms)	.05
turn off time t	(ms)	.05
Utilization categories		DC13
Function-/supply voltage indication		YES

Mechanical Data

Housing material	Polyamide
Material of sensing face	Polyamide
Connection	PVC cable
Degree of Protection	IP 67
Rated shock: half-sinus, 30 g, 11 ms	
Rated vibration environment: 55 Hz, 1mm amplitude, 3 x 30	

Electrical Data

Rated operational voltage U_e	(V)	24 DC
Supply voltage U_B	(V)	10...30 DC
incl. ripple	(% of U_e)	15
Voltage drop U_d at I_e Stat./dyn.	(V)	1/-
Rated insulation volatage U_i	(V)	75 AC
Rated supply frequency	(Hz)	DC
Rated operational current I_e	(mA)	200
No-load supply current I_o at U_e d./und.	(mA)	25/13
Protected against polarity reversal		YES





How to Order - Tiny Titan Series Piston Rod Assembly

P92 - G 1 1 N 0 - 01 A - AA

Type

- O92 = U-Cup Piston Rod Assembly
- P92 = Heavy Duty Piston Rod Assembly
- Q92 = Low Profile Piston Rod Assembly

Bore

- C = 3/4"
- E = 1"
- G = 1-1/8"

Rod Code

- 1 = Style #1 Standard Rod Diameter
- 2 = Style #2 Standard Rod Diameter
- 3 = Style #3 Standard Rod Diameter
- 6 = Style #1 Oversize Rod Diameter
- 7 = Style #2 Oversize Rod Diameter
- 8 = Style #3 Oversize Rod Diameter

Mount

- 1 = All Mounts Except F1, N1, and N2
- 2 = F1 Mount
- 3 = N1 and N2 Mount

Cushion

- N = No Cushion
- B = Both Ends Cushioned
- H = Head End Cushioned
- C = Cap End Cushioned

Magnet

- 0 = No Magnet
- 2 = Reed Magnet

Option

- AA = No Option
- EB = Silencer Bumpers
- KA = Stroke Adjuster
- NA = Nickel Plated
- 1A* = Rod Extension
- 2A* = Thread Extension
- 4A* = Stop Tube
- * Specify Length

Fractional Inches of Stroke

- A = 0" I = 1/2"
- B = 1/16" J = 9/16"
- C = 1/8" K = 5/8"
- D = 3/16" L = 11/16"
- E = 1/4" M = 3/4"
- F = 5/16" N = 13/16"
- G = 3/8" O = 7/8"
- H = 7/16" P = 15/16"

Note: 1/8" minimum stroke.

Full Inch of Stroke

- 00 = 0" Stroke
- 01 = 1" Stroke
- 02 = 2" Stroke
- 03 = 3" Stroke
- 04 = 4" Stroke
- 10 = 10" Stroke

Note: Options listed are ones that apply to a piston rod assembly only. Model number is set up to use option code supplied with original cylinder or with any above.

Rod End Styles, Diameters and Threads

Bore	Rod	Style 1	Style 2	Style 3
3/4"	0.250	1/4-28	1/4-20	6-32 X .44
3/4"	0.312	5/16-24	5/16-18	10-32 X .63
1"	0.312	5/16-24	5/16-18	10-32 X .63
1"	0.375	3/8-24	3/8-16	1/4-28 X .63
1-1/8"	0.375	3/8-24	3/8-16	1/4-28 X .63
1-1/8"	0.500	1/2-20	1/2-13	3/8-24 X .63

Jam nuts included with Style 1 and Style 2 rod ends.



Tiny Titan Series Small Bore, Square Cylinder

NUMATICS®

How to Order - Tiny Titan Series Repair Kit

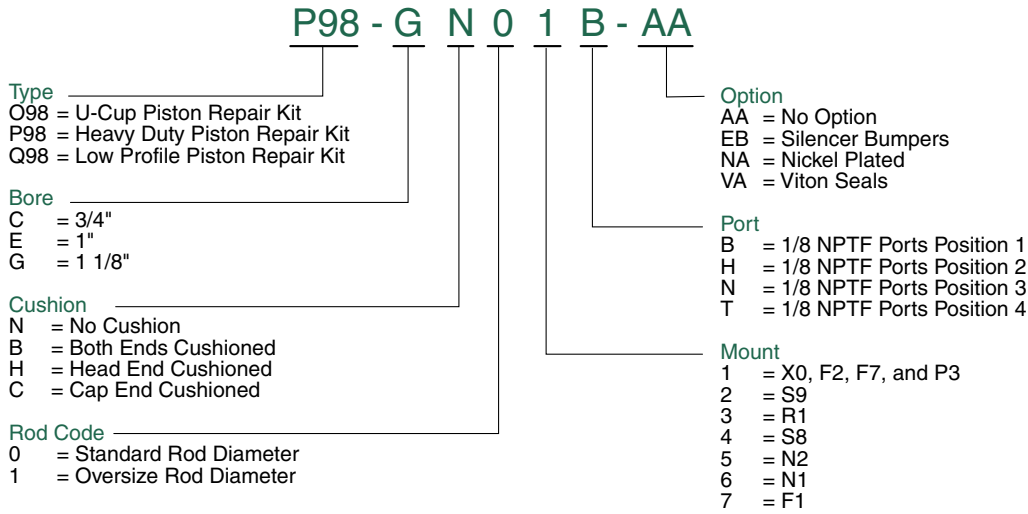

Note: Options listed are ones that apply to a repair kit only.
Model number is set up to use option code supplied with original cylinder or with any above.

How to Order - Tiny Titan Series Seal Kit

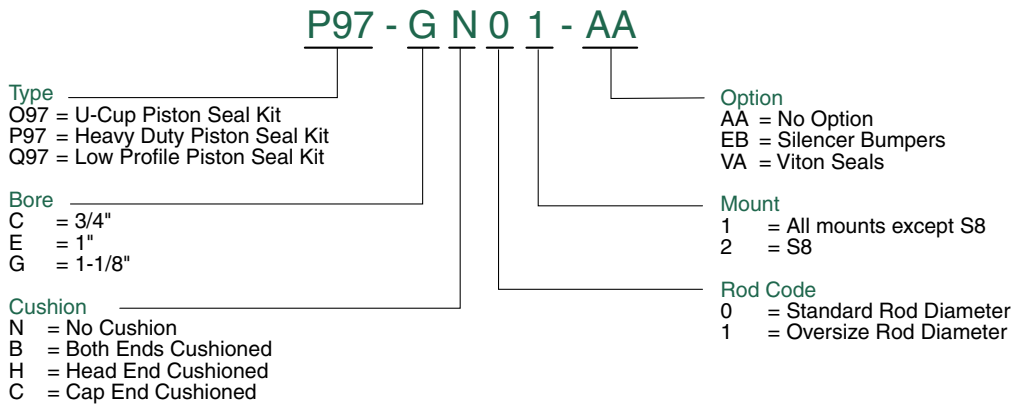

Note: Options listed are ones that apply to a seal kit only.
Model number is set up to use option code supplied with original cylinder or with any above.



Piston Rod Assembly Kit Removal/Installation Instructions

- Loosen 8 Socket Head Cap Screws (SHCS) (Part #16) to remove Head (Part #1), Piston/Rod Assembly (Part #9 & #10), and Cushion Block (Part #6) if cylinder is cushioned.
- Carefully remove old seals and wearband (Part #2, #11, #14). Depending on the cylinder type, piston seal(s) and wearband will vary. Any damage to the seal grooves may result in leakage.
- Lubricate new seals and Wearband (Part #14) with supplied Numatics' Lube. Examine seals before installing for any contamination. Contamination may cause leakage.
- Install Piston Seal(s) (Part #11). Depending on the cylinder type, piston seal(s) will vary. Make sure the piston seal is not twisted inside groove. If cylinder type is P or Q, install back-up rings (Part #12). See Seal Installation Guide.
- Install lubricated wearbands onto piston/rod assembly if cylinder type is P. Sink piston assembly into sinker tube. See Sinker Tube Part Numbers Chart.
- Apply lube inside the cylinder tube.
- Sink piston/rod assembly into cylinder tube.
- Press piston/rod assembly flush with the cylinder tube. Wipe off any lube from the face of the piston.
- Place Tube End Seals (Part #2) into head seal grooves. Examine seals after installing for any contamination. Contamination may cause leakage.
- Lightly grease Rod Seal (Part #4) in the head before reassembling the cylinder. This will ease the installation of the head over the rod.
- Carefully place head over the rod until getting interference. With a twisting motion, slide the loaded head down over the rod.
- Loosely torque head end SHCS to allow head to rotate slightly.
- Before final torque, place cylinder on level surface to square head and cap. Torque SHCS in a crisscross pattern. Use the following chart for torque tolerances.
- Stroke cylinder by hand. This will enable detection of any binding. If binding does occur, repeat steps 11-14.

Seal Installation Guide

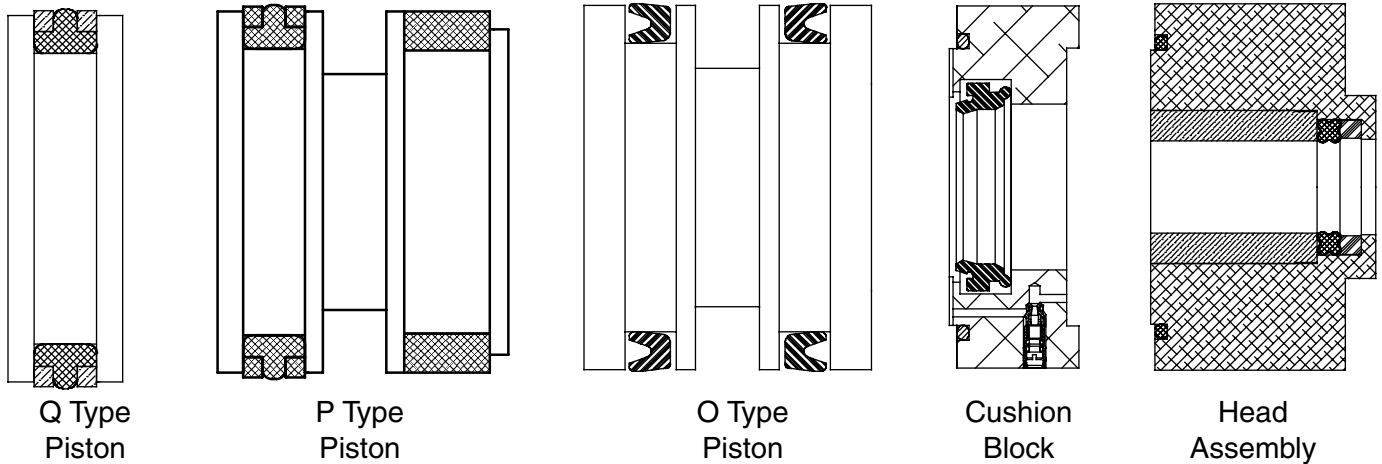

Screw Torque Tolerances (lbs-ft) Part #16

Bore	Min.	Max.
3/4	1	1.5
1	1	2
1 1/8	1	2

Sinker Tube Part Numbers

Bore	Part #
3/4	C06-C91
1	R06-E91
1 1/8	C06-G91

Note: Sinker Tubes are not included in kits. They can be ordered using the part numbers from the provided chart.



Tiny Titan Series Small Bore, Square Cylinder

NUMATICS®

Diagrams

Pneumatic Service Temperatures:
Nitrile Seals: -10°F (-23°C) to 165°F (74°C)
Viton® Seals: 0°F (-17°C) to 400°F (204°C)

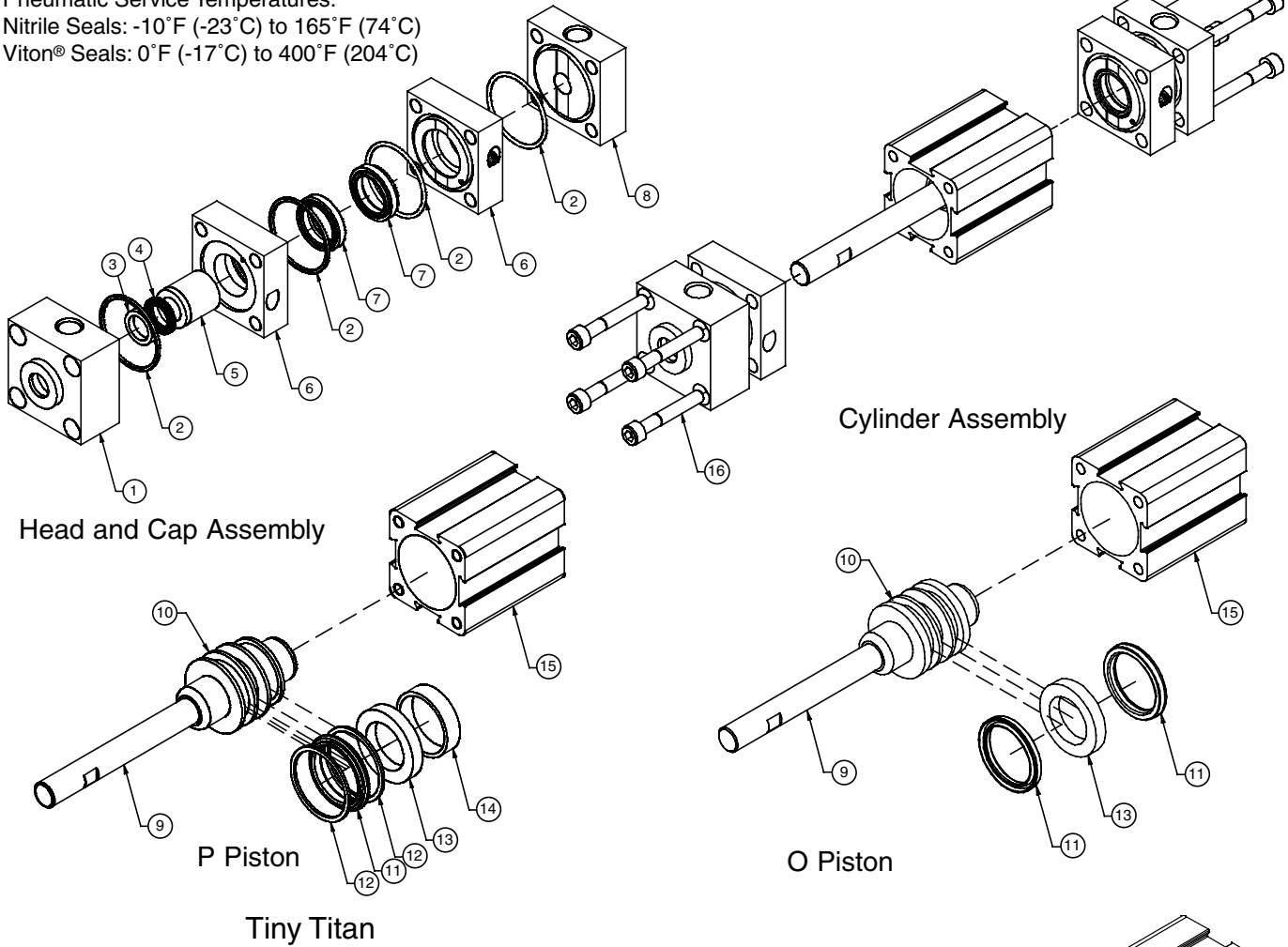

Part #	Description	Parts included in:		
		Seal Kit	Repair Kit	Piston/Rod Assembly
1	Head		X	
2	Tube End Seals	X	X	
3	Rod Wiper	X	X	
4	Rod Seal	X	X	
5	Bushing		X	
6	Cushion Block		X	
7	Cushion Seal	X	X	
8	Cap			
9	Rod			X
10	Piston			X
11	Piston Seal	X	X	
12	Back-up Rings	X	X	
13	Magnet			X
14	Wearband	X	X	
15	Tube			
16	Socket Head Cap Screws (SHCS)			

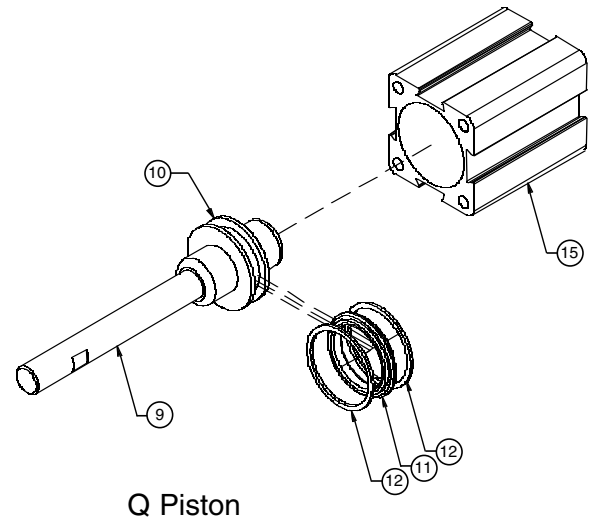



Repair Kit Removal/Installation Instructions

1. Loosen 8 Socket Head Cap Screws (SHCS) (Part #16) to remove Head (Part #1), Cap (Part #8), Piston/Rod Assembly (Part #9 & #10), and Cushion Block(s) (Part #6) if cylinder is cushioned.
2. Carefully remove old seals and wearband (Part #2, #7*, #11, #14). Depending on the cylinder type, piston seal(s) and wearband will vary. Any damage to the seal grooves may result in leakage.
3. Lubricate new seals and Wearband (Part #14) with supplied Numatics' Lube. Examine seals before installing for any contamination. Contamination may cause leakage.
4. Install Piston Seal(s) (Part #11). Depending on the cylinder type, piston seal(s) will vary. Make sure the piston seal is not twisted inside groove. If cylinder type is P or Q, install back-up rings (Part #12). See Seal Installation Guide.
5. Install lubricated wearbands onto piston/rod assembly if cylinder type is P. Sink piston assembly into sinker tube. See Sinker Tube Part Numbers Chart.
6. Apply lube inside the cylinder tube.
7. Sink piston/rod assembly into cylinder tube.
8. Press piston/rod assembly flush with the cylinder tube. Wipe off any lube from the face of the piston.
9. Place Tube End Seals (Part #2) into head and cap seal grooves. Examine seals after installing for any contamination. Contamination may cause leakage.
10. Lightly grease Rod Seal (Part #4) in the supplied loaded head before reassembling the cylinder. This will ease the installation of the head over the rod.
11. Reassemble cylinder except for the loaded head. Loosely torque cap end SHCS to allow cap to rotate slightly. Carefully place loaded head over the rod until getting interference. With a twisting motion, slide the loaded head down over the rod.
12. Loosely torque head end SHCS to allow head to rotate slightly.
13. Before final torque, place cylinder on level surface to square head and cap. Torque SHCS in a crisscross pattern. Use the following chart for torque tolerances.
14. Stroke cylinder by hand. This will enable detection of any binding. If binding does occur, repeat steps 11-14.

Seal Installation Guide

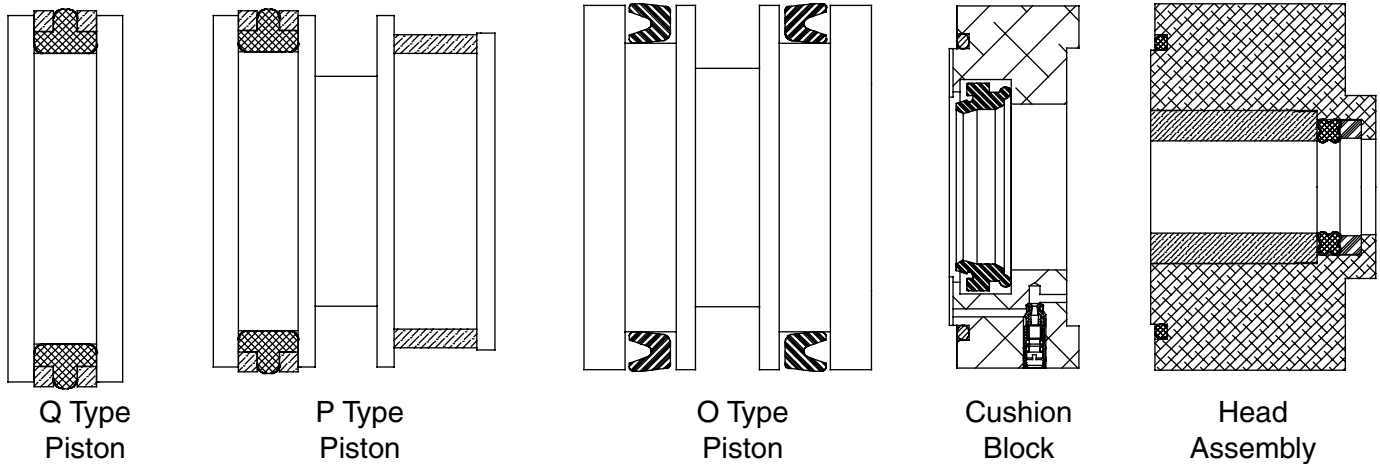

Screw Torque Tolerances (lbs-ft) Part #16

Bore	Min.	Max.
3/4	1	1.5
1	1	2
1 1/8	1	2

Sinker Tube Part Numbers

Bore	Part #
3/4	C06-C91
1	R06-E91
1 1/8	C06-G91

Note: Sinker Tubes are not included in kits. They can be ordered using the part numbers from the provided chart.



Tiny Titan Series Small Bore, Square Cylinder

NUMATICS®

Seal Kit Removal/Installation Instructions

1. Loosen 8 Socket Head Cap Screws (SHCS) (Part #16) to remove Head (Part #1), Cap (Part #8), Piston/Rod Assembly (Part #9 & #10), and Cushion Block(s) (Part #6) if cylinder is cushioned.
2. Carefully remove old seals and wearband (Part #2, #3, #4, #7, #11, #14). Depending on the cylinder type, piston seal(s) and wearband will vary. Any damage to the seal grooves may result in leakage.
3. Lubricate new seals and Wearband (Part #14) with supplied Numatics' Lube. Examine seals before installing for any contamination. Contamination may cause leakage.
4. Install Piston Seal(s) (Part #11). Depending on the cylinder type, piston seal(s) will vary. Make sure the piston seal is not twisted inside groove. If cylinder type is P or Q, install back-up rings (Part #12). See Seal Installation Guide.
5. Install lubricated wearbands onto piston/rod assembly if cylinder type is P. Sink piston assembly into sinker tube. See Sinker Tube Part Numbers Chart.
6. Apply lube inside the cylinder tube.
7. Sink piston/rod assembly into cylinder tube.
8. Press piston/rod assembly flush with the cylinder tube. Wipe off any lube from the face of the piston.
9. Place Tube End Seals (Part #2) into head and cap seal grooves. Examine seals after installing for any contamination. Contamination may cause leakage.
10. Install Rod Wiper (Part #3) and Rod Seal (Part #4) into Head (Part #1). See Seal Installation Guide. Lightly grease rod seal after installation. This will ease the installation of the head over the rod.
11. Reassemble cylinder except for the head. Loosely torque cap end SHCS to allow cap to rotate slightly. Carefully place head over the rod until getting interference. With a twisting motion, slide the head down over the rod.
12. Loosely torque head end SHCS to allow head to rotate slightly.
13. Before final torque, place cylinder on level surface to square head and cap. Torque SHCS in a crisscross pattern. Use the following chart for torque tolerances.
14. Stroke cylinder by hand. This will enable detection of any binding. If binding does occur, repeat steps 11-14.

Seal Installation Guide

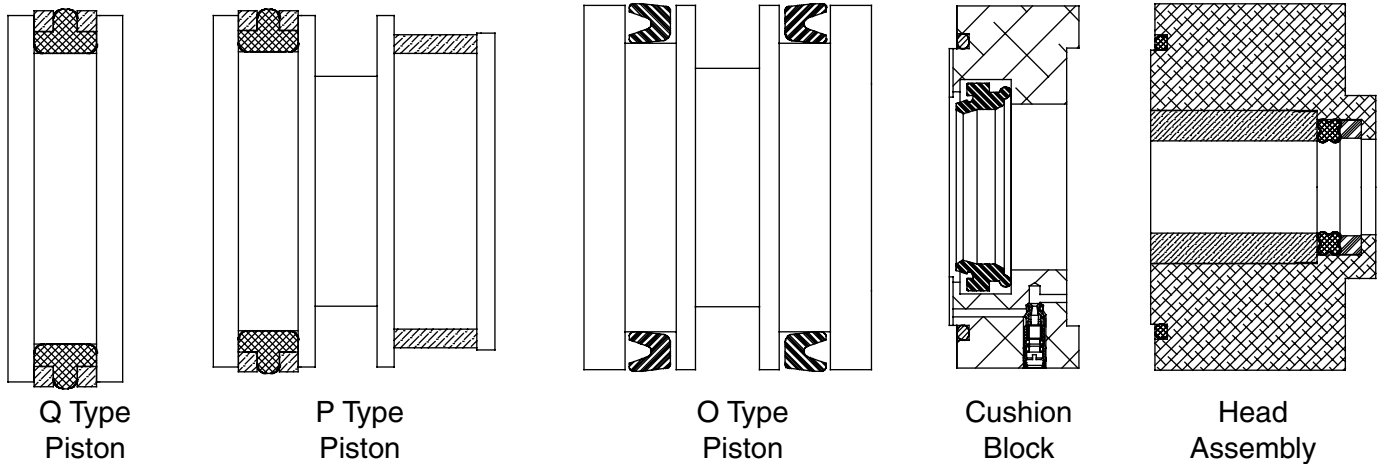

Screw Torque Tolerances (lbs-ft) Part #16

Bore	Min.	Max.
3/4	1	1.5
1	1	2
1 1/8	1	2

Sinker Tube Part Numbers

Bore	Part #
3/4	C06-C91
1	R06-E91
1 1/8	C06-G91

Note: Sinker Tubes are not included in kits. They can be ordered using the part numbers from the provided chart.

