

gantries

GS Series
Gantry Slide

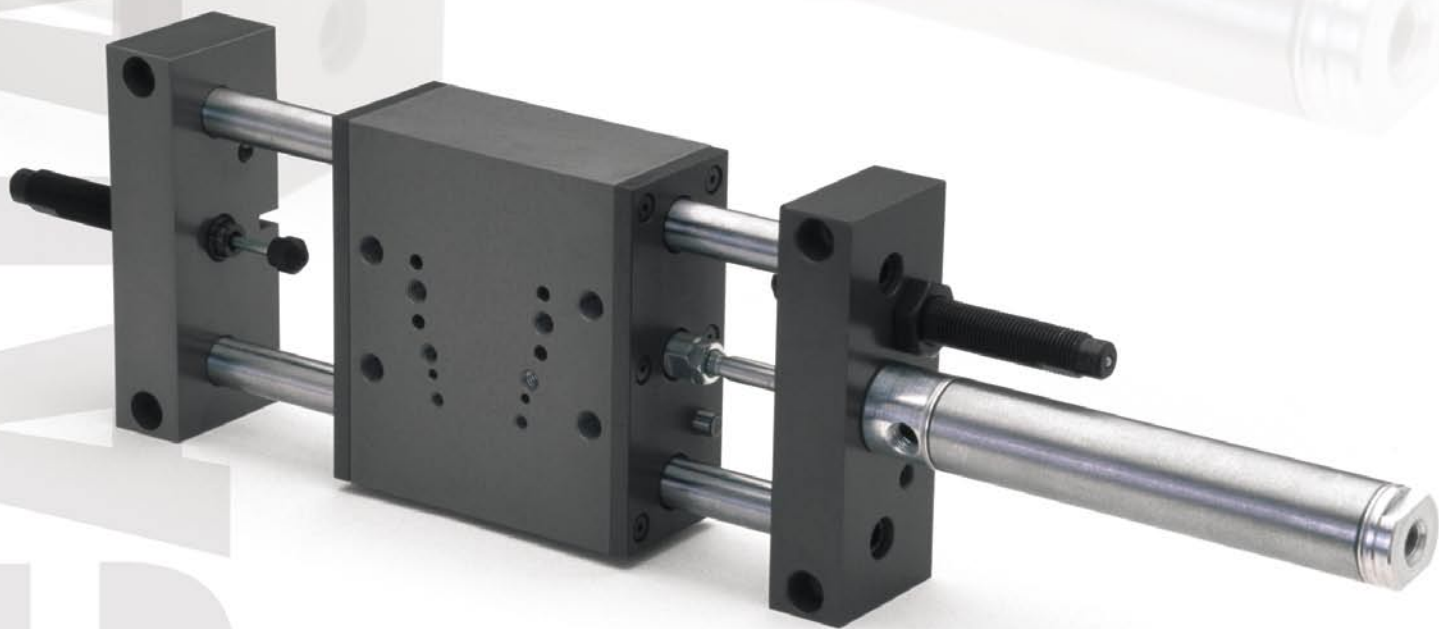

numatics

GS Series Gantry Slides	3-13
Features and Benefits	3
How To Order	4
Dimensions	5
Technical Specifications	6
Cylinder Orientation	7
Shock Absorbers	7
NuMate Mounting System	8
Multi-Position How to Order	9
Multi-Position Dimensions	10
Switch Information	11-13



Designed to handle heavier loads and travel greater distances.

The design centers around a moving carriage between two fixed tool bars. The carriage is supported and guided by four bearings and two hardened guide shafts.

A. Carriage:

Hardcoat Anodized Aluminum lightweight, high durability.
NuMate™ Direct Mounting Pattern Numate is a patented mounting system eliminating the need for adaptor/transition plates.
 Slide, gantries and grippers mount directly to the GS gantry.

B. Air Cylinder:

Standard Stainless Steel Body and Rod corrosion resistant.
 Standard Magnetic Piston sensing options Reed, Hall, Prox sensors, able to be added in field.

C. Alignment Coupler:

360 Degrees of Float isolates cylinder, eliminates destructive side load, maximizes life.

D. Tool Bars:

Standard Dowel Locating Hole and Slot accurate mounting and positioning.

Standard Tapped Holes for Shock Absorbers accepts industry standard shocks.

E. Guide Shafts: (Two Choices)

Hardened Steel hardness Rc 60-65, long life.
 Hardened Stainless Steel hardness Rc 50-55, corrosion resistant.
 Precision Ground and Polished 15u RMS smooth cycling, low breakaway.
 Large Diameter increased load capacity.
 Pilot Mounted to Tool Bar maximum rigidity, increased strength.

F. Bearings: (Two Choices)

Four Linear Ball Bearings greatest load capacity, self-lubricating, built-in seals and wipers, self-aligning.
 Four Frelon® Compounded Teflon® self-lubricating, self-aligning, long service life, ideal for cleanroom.

G. Stroke Adjustment Screws:

Standard Extend and Retract fine adjustment for carriage travel.

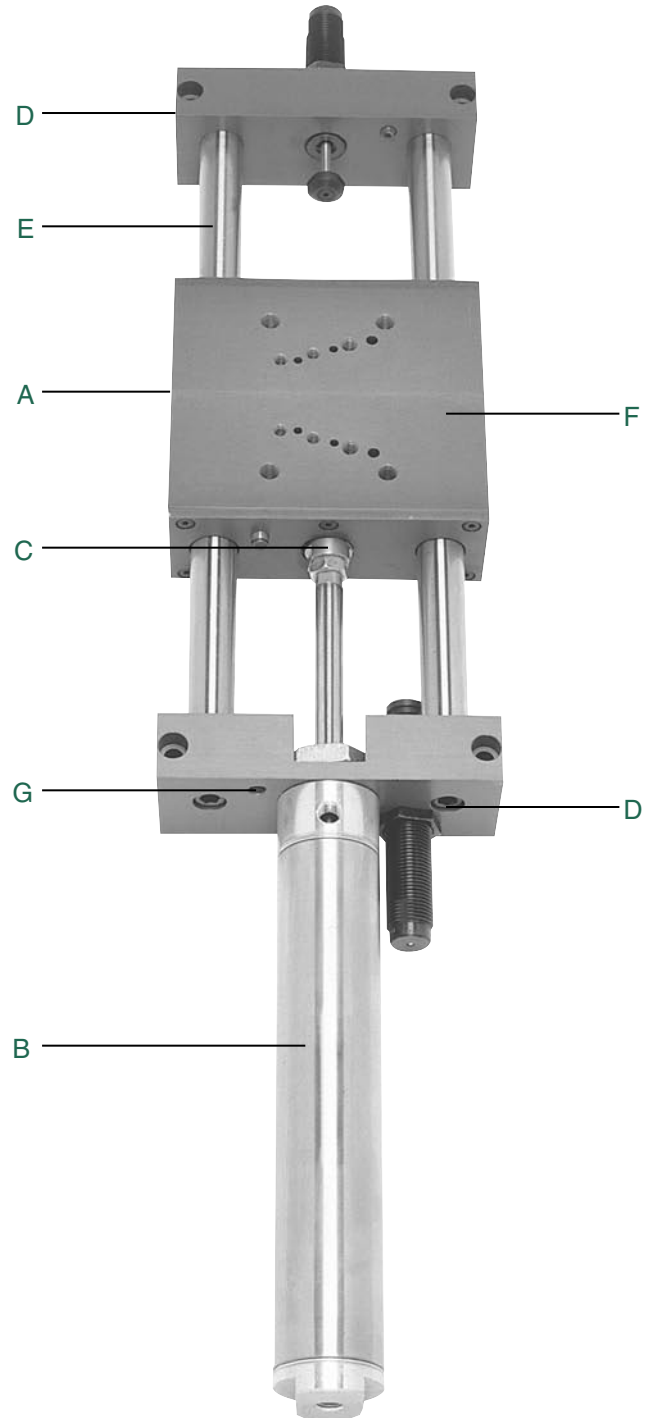



GS Series Gantry Slides

NUMATICS®

How to Order

GS 075 03 LB 1 H 3 C R 4

Bore Sizes

075 = 3/4 Inch
106 = 1-1/16 Inches
150 = 1-1/2 Inches
200 = 2 Inches

Standard Stroke

01 = 1"	13 = 13"	24 = 24"
02 = 2"	14 = 14"	25 = 25"
03 = 3"	15 = 15"	26 = 26"
04 = 4"	16 = 16"	27 = 27"
05 = 5"	17 = 17"	28 = 28"
06 = 6"	18 = 18"	29 = 29"
07 = 7"	19 = 19"	30 = 30"
08 = 8"	20 = 20"	31 = 31"
09 = 9"	21 = 21"	32 = 32"
10 = 10"	22 = 22"	33 = 33"
11 = 11"	23 = 23"	34 = 34"
12 = 12"		

Bearing Option

LB = Linear Ball
TB = Teflon®

Cylinder Type

1 – Buna-N Seals
2 – Viton Seals (no magnet)
3 – Buna-N Seals w/Cushions
4 – Viton Seal with Magnet

Guide Shaft Material

H = Hardened Steel
S = Stainless Steel (includes all stainless hardware)

Shock Absorbers

1 = Extend
2 = Retract
3 = Extend and Retract
4 = No Shocks
Reference page 7.

Cylinder Orientation

R = Right
L = Left
Reference page 7.

Sensing Position

A = Single Position Extend
B = Single Position Retract
C = Two Position Sensing
D = No Sensing

Sensing Type

Standard Cord Set

1 = Hall Effect - PNP (sourcing)
2 = Hall Effect - NPN (sinking)
3 = Reed Switch
4 = Prox Switch - PNP (sourcing)
5 = Prox Switch - NPN (sinking)
6 = No Sensing

7* = 8 mm Prox Ready

Quick Disconnect Cord Set

Z = Hall Effect - PNP (sourcing)
Y = Hall Effect - NPN (sinking)
X = Reed Switch
W = Prox Switch - PNP (sourcing) Straight
V = Prox Switch - NPN (sinking) Straight
U = Prox Switch - PNP (sourcing) 90 Deg.
T = Prox Switch - NPN (sinking) 90 Deg.

See Sensor section.

*Does not include switch.

Example order:

Part Number: GS07503LB1H3CR4*

Part Description: 3/4 bore by 3 inch stroke with linear ball bearings, standard seals, hardened steel guide shafts, reed 2 position sensing, cylinder to right, no shocks.

For Multi-Position Gantry ordering see page 9.

*When entering an order, DO NOT use spaces or dashes.

When Ordering Additional Sensors and Shocks

SWITCH DESCRIPTION	STANDARD PART NO.	QUICK DISCONNECT PART NO.
Hall Effect - PNP (Sourcing)	HPNPS31	HPNPQ31
Hall Effect - NPN (Sinking)	HNPNS32	HNPNQ32
Reed Switch	RSS02	RSQ02
Prox Switch - PNP (Sourcing)	SWPP - 0001	SWPP - QS01
Prox Switch - NPN (Sinking)	SWPN - 0001	SWPN - QS01
Prox Switch - PNP 90°	-	SWPP - QL01
Prox Switch - NPN 90°	-	SWPN - QL01
90° 5 meter cable	-	PXC 90
Straight 5 meter cable	-	PXC ST

SLIDE SERIES	SHOCK ABSORBER
GS075	SK106
GS106	SK106
GS150	SK150
GS200	SK200

*Bands and tracks required for mounting.

Reference bracket in the Switch Application Chart in the Sensor section.



GS Series Dimensions

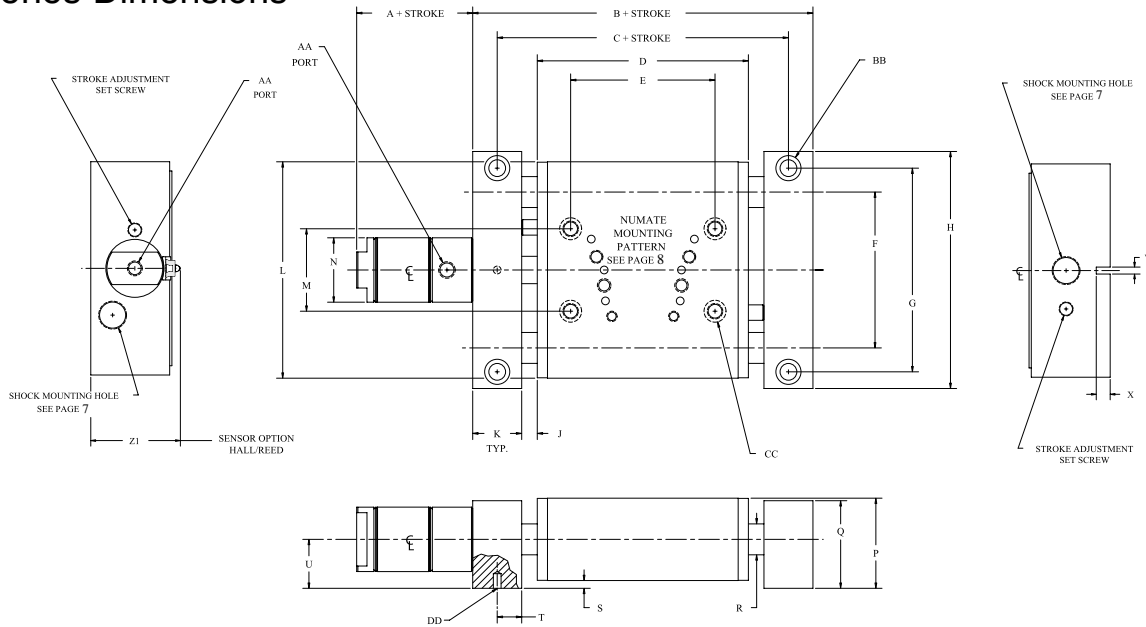

	GS075		GS106		GS150		GS200	
A	2.47	(62.7)	2.62	(66.5)	2.81	(71.4)	3.50	(88.9)
B	5.78	(146.8)	6.90	(175.3)	8.25	(209.6)	9.91	(251.7)
C	5.15	(130.8)	5.90	(149.9)	7.06	(179.3)	8.41	(213.6)
D	4.28	(108.7)	4.40	(111.8)	5.12	(130.0)	6.40	(162.6)
E	3.00	(76.2)	3.25	(82.6)	3.50	(88.9)	4.00	(101.6)
F	2.75	(69.8)	3.25	(82.6)	3.78	(96.0)	4.81	(122.2)
G	3.70	(94.0)	4.31	(109.5)	4.94	(125.5)	6.28	(159.5)
H	4.25	(108.0)	4.95	(125.7)	5.75	(146.1)	7.00	(177.8)
J	0.13	(3.3)	0.25	(6.4)	0.38	(9.7)	0.25	(6.4)
K	0.63	(16.0)	1.00	(25.4)	1.19	(30.2)	1.50	(38.1)
L	4.00	(101.6)	4.63	(117.6)	5.25	(133.4)	6.80	(172.7)
M	1.40	(35.6)	1.50	(38.1)	2.00	(50.8)	2.50	(63.5)
N	0.88	(22.4)	1.13	(28.7)	1.56	(39.6)	2.07	(52.6)
P	1.62	(41.1)	2.12	(53.8)	2.19	(55.6)	2.75	(69.8)
Q	1.50	(38.1)	2.00	(50.8)	2.13	(54.1)	2.56	(65.0)
R	0.50	(12.7)	0.63	(16.0)	0.75	(19.1)	1.00	(25.4)
S	0.38	(9.7)	0.13	(3.3)	0.19	(4.8)	0.25	(6.4)
T	0.311/0.313	(7.90/7.95)	0.499/0.501	(12.67/12.72)	0.593/0.595	(15.06/15.11)	0.749/0.751	(19.02/19.08)
U	1.00	(25.4)	1.13	(28.7)	1.19	(30.2)	1.50	(38.1)
W	0.1870/0.1880	(4.75/4.78)	0.1870/0.1880	(4.75/4.78)	0.1870/0.1880	(4.75/4.78)	0.2500/0.2510	(6.35/6.38)
X	0.30	(7.6)	0.30	(7.6)	0.30	(7.6)	0.40	(10.2)
AA	1/8 NPTF		1/8 NPTF		1/8 NPTF		1/4 NPTF	
BB	C'bored for 1/4 SHCS, Tapped 5/16-24 x 0.62 DP From Opposite Side.		C'bore for 5/16 SHCS Tapped 3/8-24 x 0.59 DP From Opposite Side.		C;bore for 5/16 SHCS, Tapped 3/8-24 x 0.59 DP From Opposite Side.		C'bore for 3/8 SHCS, Tapped 7/16-20 x 0.88 DP From Opposite Side.	
CC	Tapped 5/16-24 x .62 DP, C'bored for 1/4 SHCS, From Opposite Side.		Tapped 3/8-24 x 0.59 DP, C'bore for 5/16 SHCS From Opposite Side.		Tapped 3/8-24 x 0.59 DP, C;bore for 5/16 SHCS, From Opposite Side.		Tapped 7/16-20 x 0.88 DP, C'bore for 3/8 SHCS, From Opposite Side.	
DD	0.1870/0.1880	(4.75/4.78)	0.1870/0.1880	(4.75/4.78)	0.1870/0.1880	(4.75/4.78)	0.2500/0.2510	(6.35/6.38)
Z1	1.91	(49.0)	2.16	(55.0)	2.44	(62.0)	3.01	(76.0)

(mm)

Unit Weight Table

	GS075	GS106	GS150	GS200
Base Unit Weight (lbs.)	3.81	6.46	9.18	16.75
Adder/inch of stroke (lbs.)	0.15	0.22	0.34	0.59

Add base weight to inch adder X stroke. Sample weight calculation: Model GS075 W/6" stroke, 3.81 + (0.15 x 6) = 4.71 lbs.

Unit Output Force Table

	GS075	GS106	GS150	GS200
Extend Force (lbs.)	0.44	0.88	1.76	3.14
Retract Force (lbs.)	0.39	0.81	1.61	2.83

Multiply force factor X input pressure in PSI. Sample output force calculation: Model GS150 extend force @ 70PSI, 1.76 x 70 = 123.2 lbs.



GS Series Gantry Slides

NUMATICS®

Technical Specifications

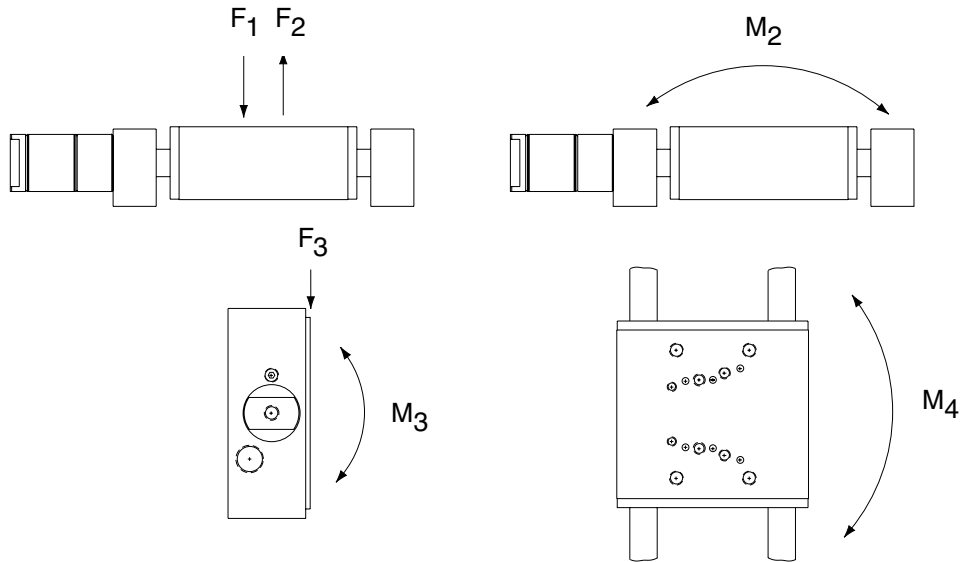

Linear Ball Bearing Dynamic Loads

SLIDE SERIES	F ₁ / F ₂ / F ₃		M ₂		M ₃		M ₄	
GS075	90 lb.	(40.8) kg.	110 in. lb.	(12.4) N.m.	222 in. lb.	(25.1) N.m.	222 in. lb.	(25.1) N.m.
GS106	160 lb.	(72.6) kg.	178 in. lb.	(20.1) N.m.	455 in. lb.	(51.4) N.m.	455 in. lb.	(51.4) N.m.
GS150	275 lb.	(124.7) kg.	262 in. lb.	(29.6) N.m.	790 in. lb.	(89.3) N.m.	790 in. lb.	(89.3) N.m.
GS200	520 lb.	(235.9) kg.	435 in. lb.	(49.1) N.m.	1657 in. lb.	(187.2) N.m.	1657 in. lb.	(187.2) N.m.

Teflon Dynamic Loads

SLIDE SERIES	F ₁ / F ₂ / F ₃		M ₂		M ₃		M ₄	
GS075	63 lb.	(28.6) kg.	77 in. lb.	(8.7) N.m.	155 in. lb.	(17.5) N.m.	155 in. lb.	(17.5) N.m.
GS106	112 lb.	(50.8) kg.	124 in. lb.	(14.0) N.m.	318 in. lb.	(35.9) N.m.	318 in. lb.	(35.9) N.m.
GS150	193 lb.	(87.5) kg.	183 in. lb.	(20.7) N.m.	553 in. lb.	(62.5) N.m.	553 in. lb.	(62.5) N.m.
GS200	364 lb.	(165.1) kg.	304 in. lb.	(34.3) N.m.	1159 in. lb.	(130.9) N.m.	1159 in. lb.	(130.9) N.m.

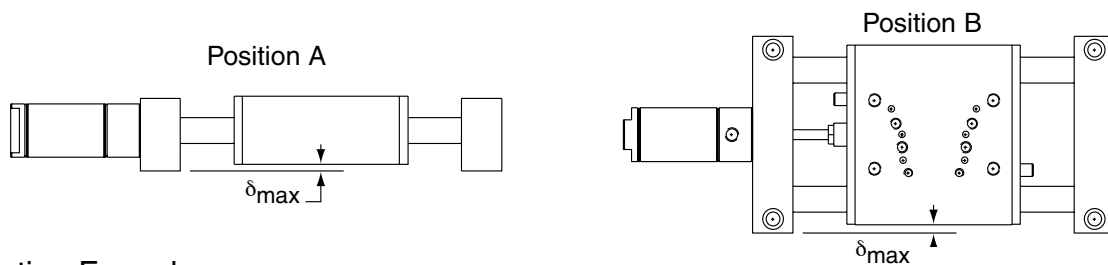

Deflection Formulas

	POSITION A	POSITION B
GS075	$\delta_{\max} = (\text{LOAD}) \left(\left(\frac{\text{STROKE}}{2} \right) - 1.325 \right)^3 \left(2 + \frac{15.9}{\text{STR}_{\text{OKE}-2.65}} \right) 1.1331 \times 10^{-7}$	$\delta_{\max} = (\text{LOAD}) \left(\left(\frac{\text{STROKE}}{2} \right) - 1.325 \right)^3 \left(2 + \frac{15.9}{\text{STR}_{\text{OKE}-2.65}} \right) 7.9317 \times 10^{-8}$
GS106	$\delta_{\max} = (\text{LOAD}) \left(\left(\frac{\text{STROKE}}{2} \right) - 1.200 \right)^3 \left(2 + \frac{19.5}{\text{STR}_{\text{OKE}-2.40}} \right) 4.6491 \times 10^{-8}$	$\delta_{\max} = (\text{LOAD}) \left(\left(\frac{\text{STROKE}}{2} \right) - 1.200 \right)^3 \left(2 + \frac{19.5}{\text{STR}_{\text{OKE}-2.40}} \right) 3.2544 \times 10^{-8}$
GS150	$\delta_{\max} = (\text{LOAD}) \left(\left(\frac{\text{STROKE}}{2} \right) - 1.500 \right)^3 \left(2 + \frac{18.0}{\text{STR}_{\text{OKE}-3.00}} \right) 2.2515 \times 10^{-8}$	$\delta_{\max} = (\text{LOAD}) \left(\left(\frac{\text{STROKE}}{2} \right) - 1.500 \right)^3 \left(2 + \frac{18.0}{\text{STR}_{\text{OKE}-3.00}} \right) 1.5761 \times 10^{-8}$
GS200	$\delta_{\max} = (\text{LOAD}) \left(\left(\frac{\text{STROKE}}{2} \right) - 1.828 \right)^3 \left(2 + \frac{21.9}{\text{STR}_{\text{OKE}-3.66}} \right) 7.1055 \times 10^{-9}$	$\delta_{\max} = (\text{LOAD}) \left(\left(\frac{\text{STROKE}}{2} \right) - 1.828 \right)^3 \left(2 + \frac{21.9}{\text{STR}_{\text{OKE}-3.66}} \right) 4.9739 \times 10^{-9}$

LOAD and STROKE values input by customer.

Sample Deflection Calculation: GS10605 with 110# load in Position A

$$\delta_{\max} = (110) \left(\left(\frac{5}{2} \right) - 1.200 \right)^3 \left(2 + \frac{19.5}{5-2.40} \right) 4.6491 \times 10^{-8} : \delta_{\max} = (110) (1.300)^3 (2+7.5) 4.6491 \times 10^{-8} = 0.00011 \text{ inch at mid travel}$$



Cylinder Orientation

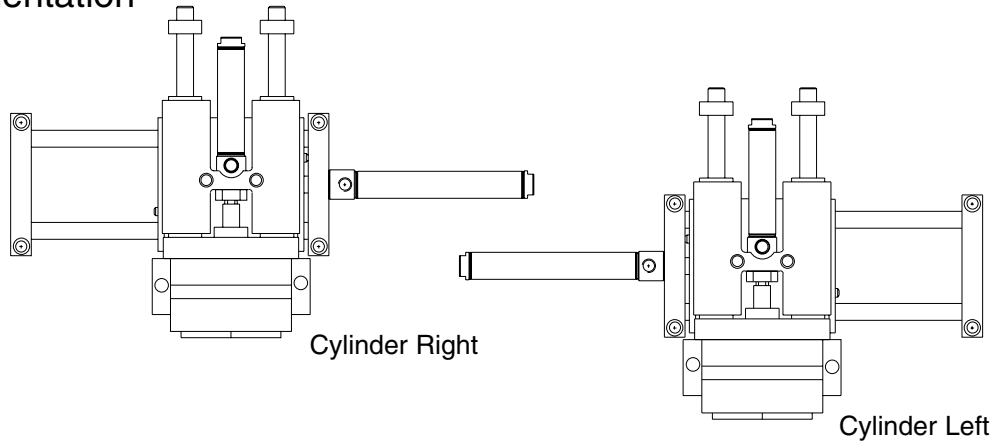

Shock Absorbers

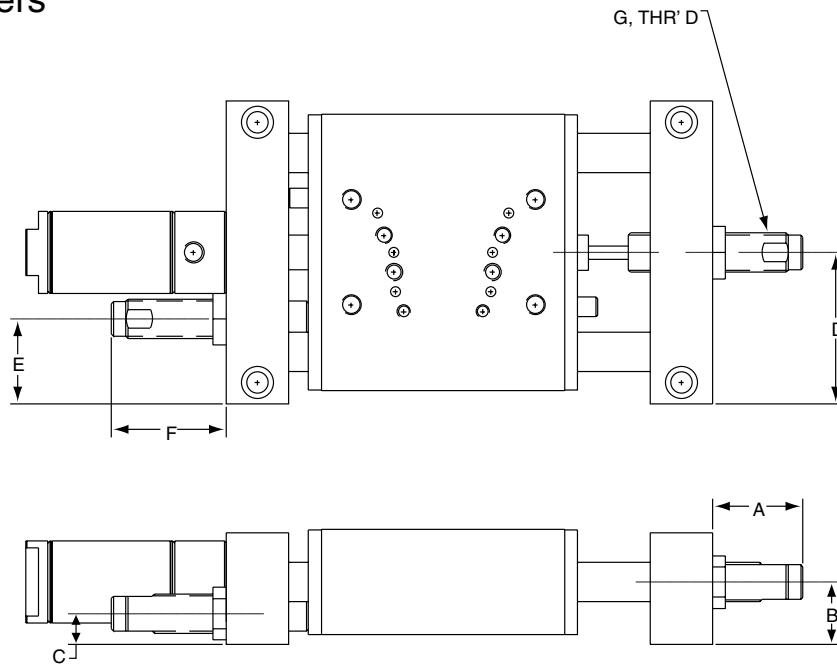

Dimensions

	GS075		GS106		GS150		GS200	
A	2.78	(70.6)	2.21	(56.1)	1.72	(43.7)	2.34	(59.4)
B	1.00	(25.4)	1.13	(28.7)	1.19	(30.2)	1.50	(38.1)
C	0.61	(15.5)	0.63	(16.0)	0.59	(15.0)	0.74	(18.8)
D	2.13	(54.1)	2.48	(63.0)	2.88	(73.2)	3.50	(88.9)
E	1.20	(30.5)	1.48	(37.6)	1.62	(41.1)	1.85	(47.0)
F	3.12	(79.2)	2.62	(66.5)	2.19	(55.6)	2.87	(72.9)
G	9/16 - 18		9/16 - 18		3/4 - 16		1 - 12	
(mm)								

Shock Absorbers

	GS075	GS106	GS150	GS200
PART NO.	SK106	SK106	SK150	SK200



GS Series Gantry Slides

NUMATICS®

NuMate Mounting System

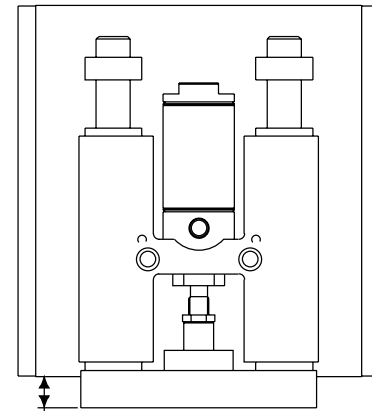
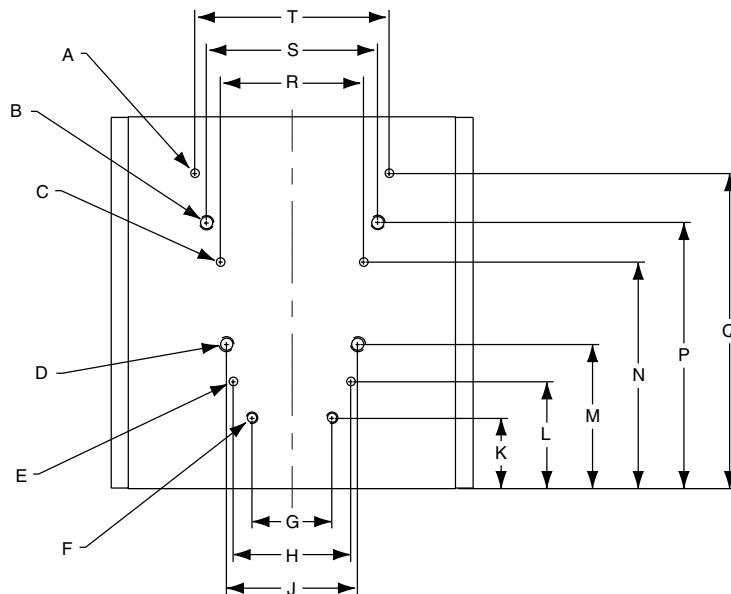

NuMate™ Pattern Dimensional Data

	GS075	GS106	GS150	GS200
A	0.187/0.188 x 0.37 DP	0.187/0.188 x 0.37 DP	0.187/0.188 x 0.37 DP	0.250/0.251 x 0.50 DP
B	1/4-20 x 0.37 DP	5/16-18 x 0.50 DP	5/16-18 x 0.50 DP	3/8-16 x 0.60 DP
C	0.125/0.126 x 0.25 DP	0.187/0.188 x 0.37 DP	0.187/0.188 x 0.37 DP	0.187/0.188 x 0.37 DP
D	#10-32 x 0.33 DP	1/4-20 x 0.37 DP	5/16-18 x 0.50 DP	5/16-18 x 0.50 DP
E	.0937/.0947 x 0.18 DP	0.125/0.126 x 0.25 DP	0.187/0.188 x 0.37 DP	0.187/0.188 x 0.37 DP
F	#6-32 x 0.22 DP	#10-32 x 0.33 DP	1/4-20 x 0.37 DP	5/16-18 x 0.50 DP
G	1.00 (25.4)	1.25 (31.8)	1.50 (38.1)	1.87 (47.5)
H	1.00 (25.4)	1.38 (35.1)	1.81 (46.0)	1.87 (47.5)
J	1.25 (31.8)	1.50 (38.1)	1.87 (47.5)	2.25 (57.2)
K	1.12 (28.4)	1.38 (35.1)	1.50 (38.1)	2.38 (60.5)
L	1.33 (33.8)	1.69 (42.9)	1.87 (47.5)	2.76 (70.1)
M	1.52 (38.6)	1.94 (49.3)	2.25 (57.2)	3.08 (78.2)
N	1.83 (46.5)	2.31 (58.7)	2.63 (66.8)	3.52 (89.4)
P	2.13 (54.1)	2.69 (68.3)	2.95 (74.9)	3.87 (98.3)
Q	2.50 (63.5)	3.06 (77.7)	3.38 (85.9)	4.37 (111.0)
R	1.38 (35.1)	1.81 (46.0)	1.87 (47.5)	2.50 (63.5)
S	1.50 (38.1)	1.87 (47.5)	2.25 (57.2)	2.75 (69.8)
T	1.81 (46.0)	1.87 (47.5)	2.50 (63.5)	3.00 (76.2)

(mm)

NuMate™ Compatibility Table & Edge Reference

	GS075	GS106	GS150	GS200
SH031	0.15 (3.8)			
SH056	0.36 (9.1)	0.50 (12.7)		
SH075	0.21 (5.3)	0.40 (10.2)	0.84 (21.3)	
SH106		0.22 (5.6)	0.65 (16.5)	0.52 (13.2)
SH150			0.30 (7.6)	0.16 (4.1)
SH200				0.13 (3.3)
LC056	-0.28 (-7.1)	-0.14 (-3.6)		
LC075	-0.54 (-13.7)	-0.35 (-8.9)	0.09 (2.3)	
LC106		-0.85 (-21.6)	-0.41 (-10.4)	-0.54 (-13.7)
LC150			-0.89 (-22.6)	-1.02 (-25.9)
B04	0.09 (2.3)	0.24 (6.1)		
B06	0.26 (6.6)	0.40 (10.2)		
B08	0.84 (21.3)	0.99 (25.2)		

(mm)

8

Information subject to change without notice. For ordering information or regarding your local sales office visit www.numatics.com.



How to Order

3 Position Gantry Slide

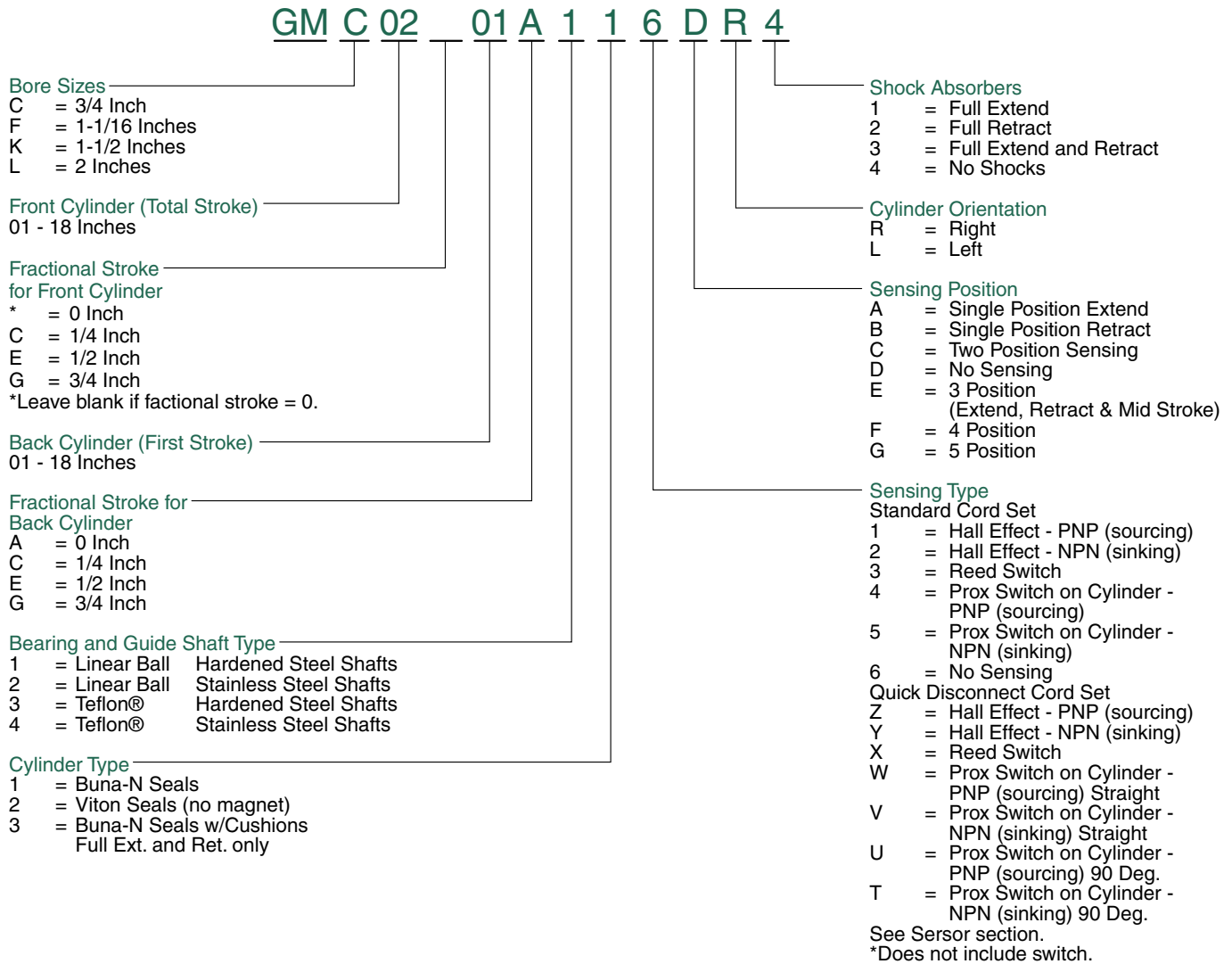



GS Series Gantry Slides

NUMATICS®

3 Position Gantry Slide

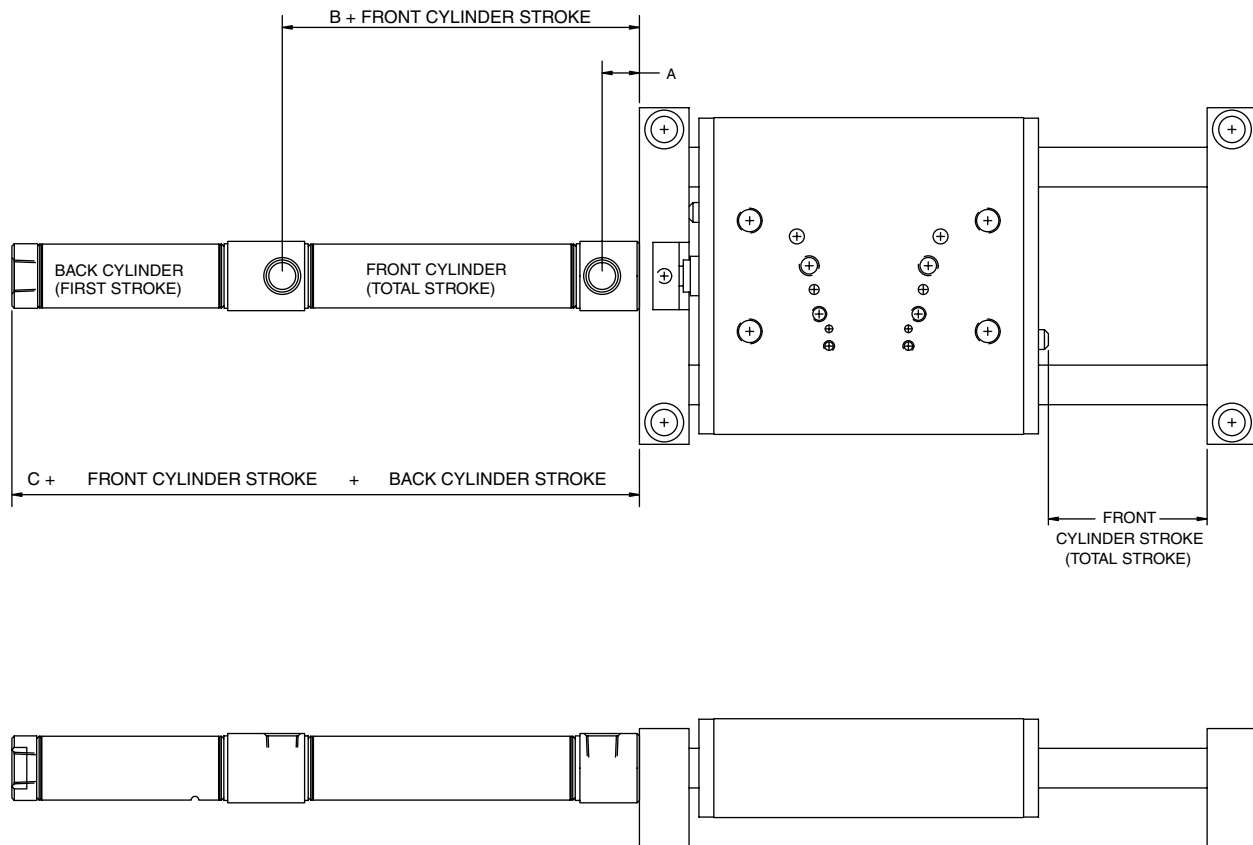

Dimensions - Inches

GS SERIES	A	B	C
GS075	0.47	2.50	4.91
GS106	0.56	2.59	5.16
GS150	0.63	2.75	5.56
GS200	0.74	3.45	6.93



GS Series Switch Information

	SWITCH OR BRACKET DESCRIPTION	STANDARD PART NO.	QUICK DISCONNECT PART NO.
1	Hall Effect - PNP (Sourcing)	HPNPS31	HPNPQ31
1	Hall Effect -NPN (Sinking)	HNPNS32	HNPNQ32
1	Reed Switch	RSS02	RSQ02
2	Short Switch Bracket	SBS-1	SBS-1
2	Long Switch Bracket**	SBL-2	SBL-2
3	Switch Band Clamp	SBC###*	SBC###*
4	Prox Switch - PNP (Sourcing)	SWPP-0001	SWPP-QS01
4	Prox Switch - NPN (Sinking)	SWPN-0001	SWPN-QS01

*Use the 3 digit bore size with "SBC" number to complete part number
Example: GS15003LB1H3CR4 = Switch Band clamp p/n: SBC150

** Long bracket used on strokes of 1" or less with two position sensing.

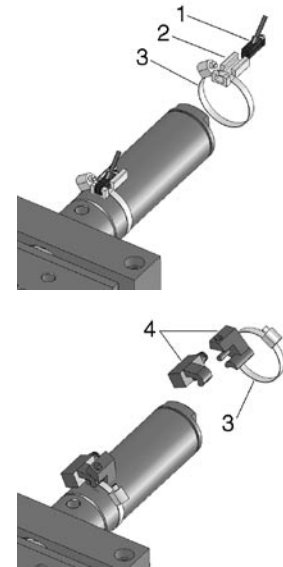

RSS02 – Reed Switch (AC/DC NO), flying lead

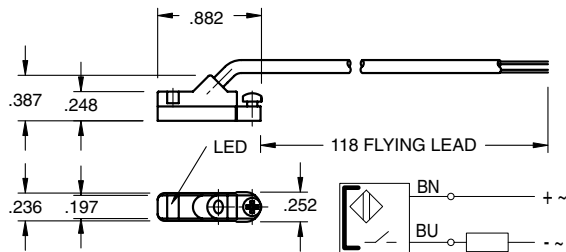

Sensing Data

Ambient temperature range T_a	(°F/°C)	-4 to 176 (-20 to 80)
Frequency of operating cycles f at U_e	(kHz)	0.5
Turn on time t	(ms)	≤ 0.25
turn off time t	(ms)	0.03
LED function indication		yes

Electrical Data

Rated operational voltage U_e	(V)	3...130 AC/DC
Supply voltage U_B	(V)	3...130 AC/DC
Voltage drop U_d at I_e Stat./dyn.	(V)	3.5
Rated insulation volatage U_i	(V)	2750 DC (EN 60335-1)
Rated supply frequency	(Hz)	AC/DC
Rated operational current I_e	(mA)	50 (10W max.)
No-load supply current I_o at U_e d./und.	(mA)	0

Observe polarity for correct LED function

RSQ02 – 8mm connector

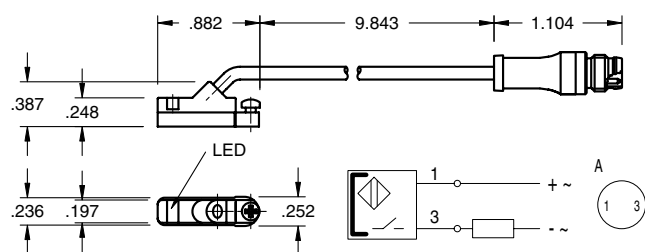

Mechanical Data

Housing material	Polyamide
Material of sensing face	Polyamide
Connection	PVC cable
Degree of Protection	IP 67
Rated shock: half-sinus, 50g, 11 ms	
Rated vibration environment: 10g, 10...2000 Hz. 90 min	





GS Series Gantry Slides

NUMATICS®

HPNPS31 – Electronic Switch (PNP NO), flying lead

HPNPQ31 – 8mm connector

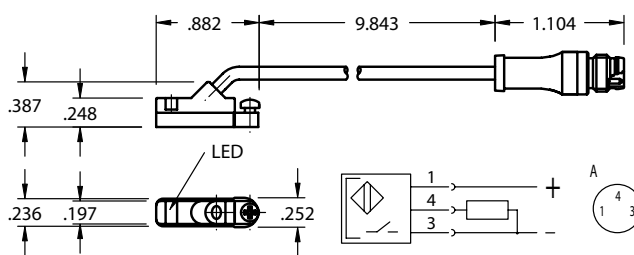
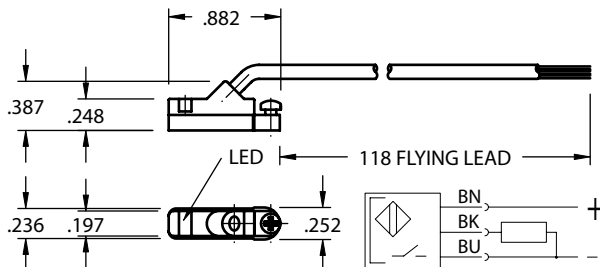

Sensing Data

Ambient temperature range θ_d	(°F/°C)	-13 to +158 (-25 to +70)
Temperature drift	(% of)	$\leq 0.3\%/^{\circ}\text{C}$
Frequency of operating cycles f at U_e	(kHz)	10
Turn on time t	(ms)	.05
Turn off time t	(ms)	.05
Utilization categories		DC13
Function—supply voltage indication		YES

Electrical Data

Rated operational voltage U_e	(V)	24 DC
Supply voltage U_B	(V)	10...30 DC
incl. ripple	(% of U_e)	15
Voltage drop U_d at I_e Stat./dyn.	(V)	1/-
Rated insulation voltage U_i	(V)	75 AC
Rated supply frequency	(Hz)	DC
Rated operational current I_e	(mA)	200
No-load supply current I_o at U_e d./und.	(mA)	25/13
Protected against polarity reversal		YES

Mechanical Data

Housing material	Polyamide
Material of sensing face	Polyamide
Connection	PVC cable
Degree of Protection	IP 67
Rated shock: half-sinus, 30 g, 11 ms	
Rated vibration environment: 55 Hz, 1mm amplitude, 3 x 30	



HNPNS32 – Electronic Switch (NPN NO), flying lead

HNPNQ32 – 8mm connector

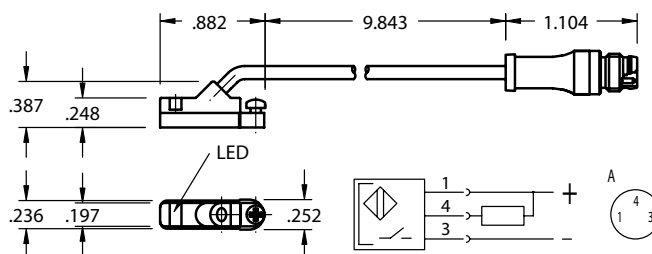
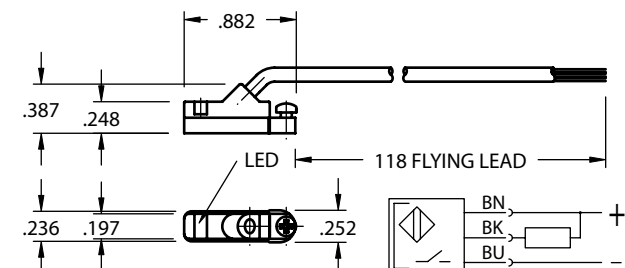

Sensing Data

Ambient temperature range θ_d	(°F/°C)	-13 to +158 (-25 to +70)
Temperature drift	(% of S_r)	$\leq 0.3\%/^{\circ}\text{C}$
Frequency of operating cycles f at U_e	(kHz)	10
Turn on time t	(ms)	.05
Turn off time t	(ms)	.05
Utilization categories		DC13
Function—supply voltage indication		YES

Electrical Data

Rated operational voltage U_e	(V)	24 DC
Supply voltage U_B	(V)	10...30 DC
incl. ripple	(% of U_e)	15
Voltage drop U_d at I_e Stat./dyn.	(V)	1/-
Rated insulation voltage U_i	(V)	75 AC
Rated supply frequency	(Hz)	DC
Rated operational current I_e	(mA)	200
No-load supply current I_o at U_e d./und.	(mA)	25/13
Protected against polarity reversal		YES

Mechanical Data

Housing material	Polyamide
Material of sensing face	Polyamide
Connection	PVC cable
Degree of Protection	IP 67
Rated shock: half-sinus, 30 g, 11 ms	
Rated vibration environment: 55 Hz, 1mm amplitude, 3 x 30	





SWPP-0001 (PNP NO), flying lead
SWPN-0001 (NPN NO), flying lead

SWPP-QS01 – 8 mm connector
SWPN-QS01 – 8 mm connector

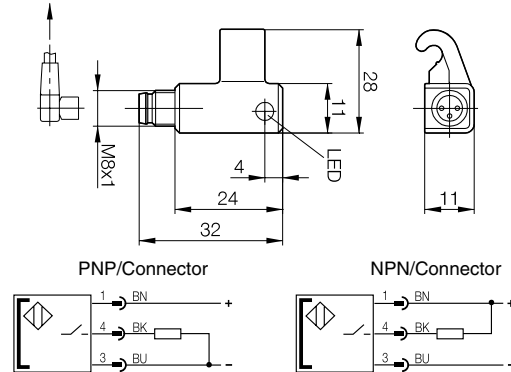
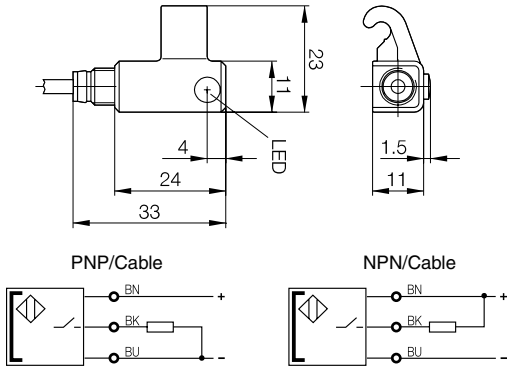

Hysteresis of I_{Hn} I
Temperature drift of turn-on point of I_{Hn} I
Turn-on delay
Turn-off delay
Supply voltage U_B
Voltage drop U_d
Rated insulation voltage U_i
Rated operating current I_e
No-load supply current I_0 max.
Off-state current I_r
Protected against polarity reversal
Short circuit protected
Load capacitance
Ambient temperature range T_a
Utilization category
Degree of protection per IEC 60529
Housing material

$\leq 45\%$
 $\leq 0.3\%/^{\circ}\text{C}$
 ≤ 0.5 ms
 ≤ 0.5 ms
10...30 Vdc
 ≤ 3.1 V
75 Vdc
200 mA¹
 ≤ 30 mA
 ≤ 80 μA
yes
yes
 ≤ 1 μF
-25°C...+70°C
DC 13
IP 67
PBT Hardened

Female Connectors for Reed Switches and Hall Effect Sensors

Dimensions (mm)

TYPE	ORDER CODE
Straight, 5 m Cable	PXCST
Elbow, 5 m Calbe	PXC90

Straight Type

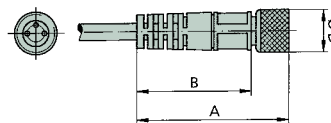

Elbow Type

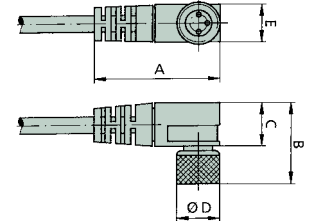

NUMATICS®

World Class Supplier
of Pneumatic Components



World Headquarters

Numatics Incorporated

Phone: 248-887-4111
Fax: 248-887-9190

UNITED STATES

Numatics – Air Preparation

Phone: 810-667-3900
Fax: 810-667-3902

Numatics – Valves

Phone: 248-887-4111
Fax: 248-887-9190

Numatics – Miniature Valves

Phone: 248-960-1400
Fax: 248-960-2160

Numatics – Cylinders

Phone: 615-771-1200
Fax: 615-771-1201

Numatics – Rodless Cylinders

Phone: 519-452-1777
Fax: 519-452-3995

Numatics – Automation

Phone: 440-934-3200
Fax: 440-934-2288

CANADA

Ontario

Numatics, Ltd.
Phone: 519-452-1777
Fax: 519-452-3995

Quebec

Numatics, Ltd.
Phone: 514-332-6444
Fax: 514-332-9273

British Columbia

Numatics, Ltd.
Phone: 604-574-0401
Fax: 604-574-3713

EUROPE

Germany – European Headquarters

Numatics GmbH
Phone: 011-49-22 41-31 60-0
Fax: 011-49-22 41-31 60 40

Hungary

Numatics Kft.
Phone: 011-36-13 82 21 35
Fax: 011-36-12 04 39 47

EUROPE

England

Numatics Limited
Phone: 011-44-1525-37 07 35
Fax: 011-44-1525-38 25 67

France

Numatics s.a.r.l.
Phone: 011-33-1 41 21 48 88
Fax: 011-33-1 41 21 48 89

Italy

Numatics srl
Phone: 011-39-030-373 19 99
Fax: 011-39-030-373 19 81

Netherlands

Numatics B.V.
Phone: 011-31-418-65 29 50
Fax: 011-31-418-65 29 43

Spain

Numatics Spain S.L.
Phone: 011-34-93-221 21 96
Fax: 011-34-93-221 35 14

AFRICA

South Africa

Numatics SA (Pty) Ltd.
Phone: 011-27-11-8 65 44 52
Fax: 011-27-11-8 65 42 90

LATIN & SOUTH AMERICA

Mexico

Numatics de Mexico S.A. de C.V.
Phone: 011-52-222-284 6176
Fax: 011-52-222-284 6179

Brazil

Valvair Comercial Ltda.
Phone: 011-55-12-351 2874
Fax: 011-55-12-351 1958

ASIA & PACIFIC

Australia

Numatics Australia Pty. Ltd.
Phone: 011-61-3-95 63 86 00
Fax: 011-61-3-95 63 85 11

Taiwan – Asian Headquarters

Numatics Co, Ltd. Asia
Phone: 011-886-2-29 15 16 05
Fax: 011-886-2-29 14 18 97

For a comprehensive listing of all Numatics production and distribution facilities worldwide, visit www.numatics.com