

KOBOLD DMI Series Magnetic Flowmeter

User Instructions

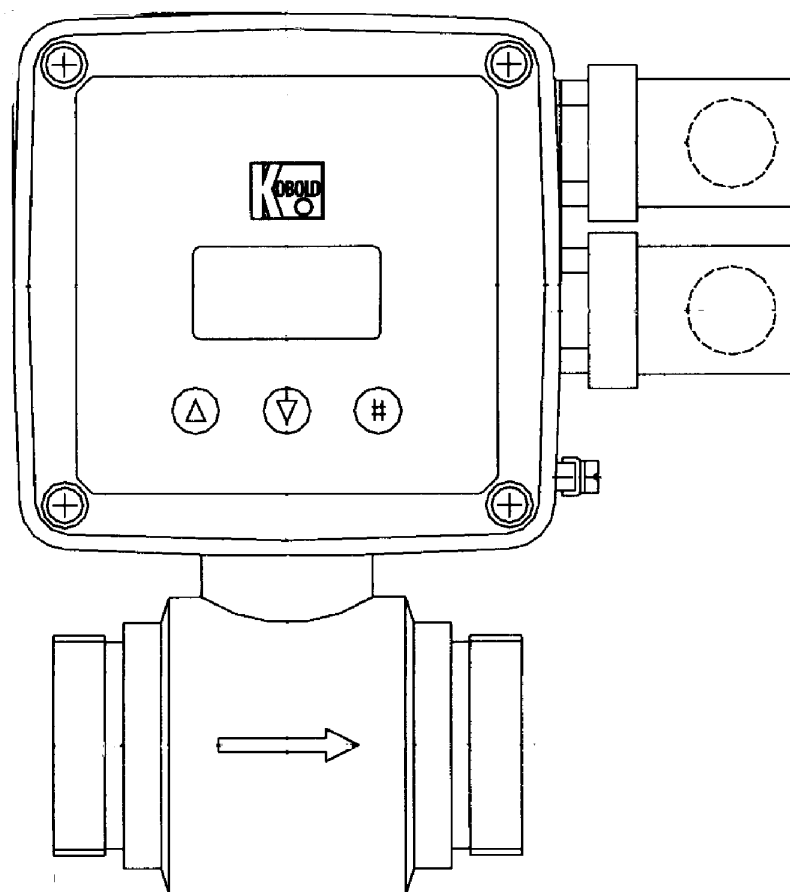

KOBOLD Instruments Inc. 1801 Parkway View Drive Pittsburgh PA 15205

Phone (412) 788-2830 Fax (412)-788-4890 www.koboldusa.com

Table Of Contents

- 1.0 General 1
- 2.0 Specifications 1
- 3.0 Mechanical Installation 4
- 3.1 Installation Requirements and Precautions 4
- 4.0 Electrical Connections 6
- 4.1 Grounding 6
- 5.0 Operation 7
- 5.1 Factory Default Settings 7
- 5.2 Programming General 8
- 5.3 Programming Steps 9
- 6.0 Maintenance 14

List of Tables

- Table 2.1 Part Number Identification 2
- Table 3.1 Inlet and Outlet Piping Requirements 6
- Table 5.1 DMI Factory Default Settings 7

List of Diagrams

- Diagram 2.1 Dimensions 3
- Diagram 4.1 Grounding 6
- Diagram 4.2 Electrical Wiring 7

CAUTION: For safety reasons, please read the cautionary information located at the end of the manual, before attempting installation.

1.0 General

The KOBOLD series DMI operates based on the magneto-inductive measuring principle. A voltage is applied to coils which are placed in the body of the flowmeter. These coils generate a magnetic field around the meter's flow body. When electrically conductive liquid passes through the magnetic field an electrical current is generated in the liquid. The magnitude of the generated current is proportional to the liquid flowrate. The current is collected by electrodes mounted in the flow body. This current signal is then processed into a flowrate output. The DMI series had a standard LCD rate/total display and open collector transistor output which can be configured either as a flowrate switch or pulse flow transmitter. The DMI series is offered in body materials of either polyetheretherketone (PEEK) or polyethylene terephthalate (PETP) with Hastelloy C measuring electrodes.

2.0 Specifications

Max. Operating Pressure:	145 PSIG
Max. Process Temperature	
PEEK Body:	-10 to 230°F
PETP Body:	-10 to 140°F
Minimum Liquid Conductivity:	50uS/cm
Materials of Construction	
Body:	PEEK or PETP
Electrodes:	Hastelloy C
Accuracy:	±3% of rate for flow > 0.07 X flow _{max} ± 0.0021 X flow _{max} for flow < 0.07 X flow _{max}
Optional:	±1.5% of rate for flow > 0.07 X flow _{max} ± 0.001 X flow _{max} for flow < 0.07 X flow _{max}
Repeatability:	±0.2% of flowrate
Creep Suppression:	Adjustable from 1 to 10% of full scale
Response Time:	Adjustable from 5-40 seconds

Electrical Specifications

Power Requirements:	24 VAC/VDC +10%/-20% @ 6 VA max
Electrical Concessions	Plug per DIN 43650 (Hirschman style)
Coil Excitation Frequency:	6.25 Hz
Warm-Up time:	30 minutes
Display:	Two line LCD rate and total, Selectable between US and metric units

Electrical Specifications (cont.)

Switch Output:	NPN open collector selectable as a flow rate alarm, flow direction signal, system error alarm, or pulse transmitter
Pulse Width:	20 mSec max
Pulse Frequency:	20 Hz Max.
Max. Voltage:	30 VDC
Max. Current:	220 mA DC
Analog output (optional)	scalable 4-20 mA Max Load 600 Ohm
Electrical Protection:	NEMA 4X/IP65

Table 2.1 Part Number Identification

DMI- = Plastic Body magnetic Flowmeter

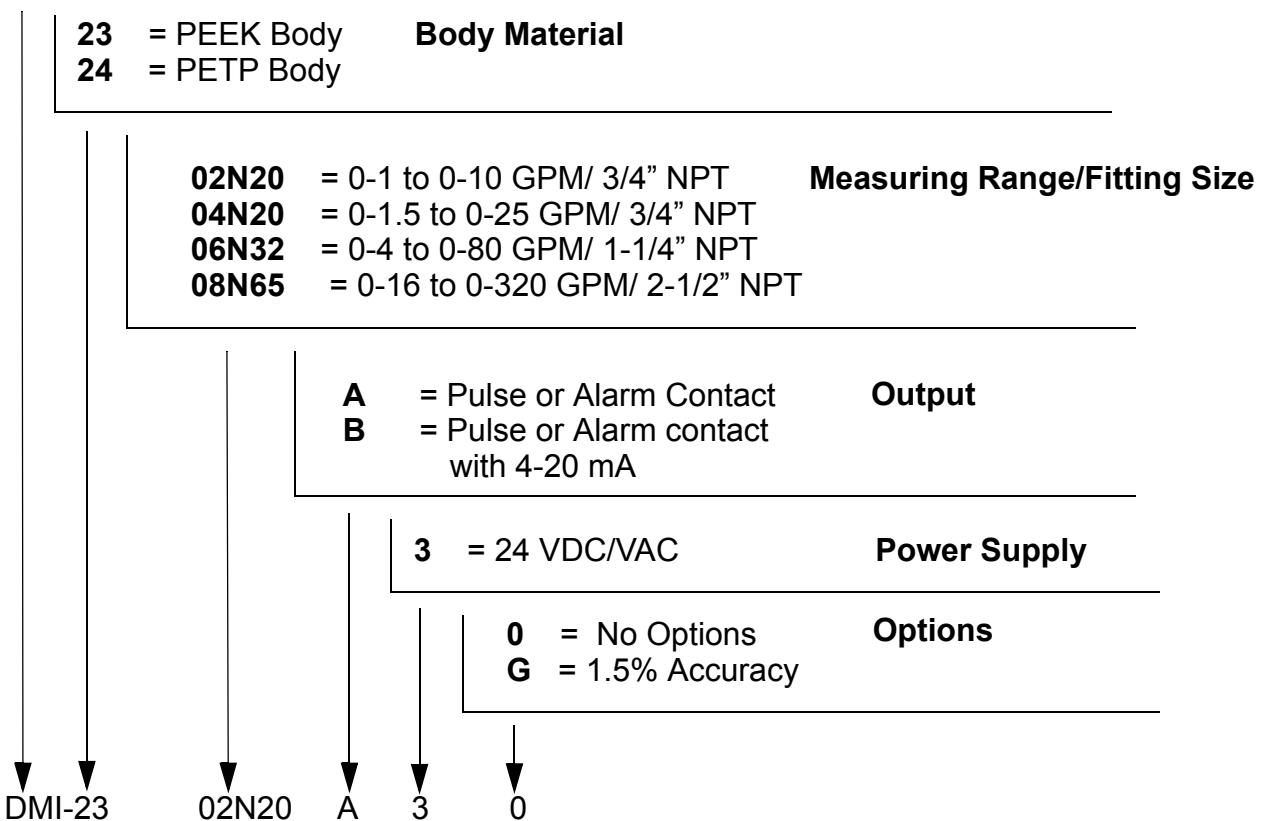
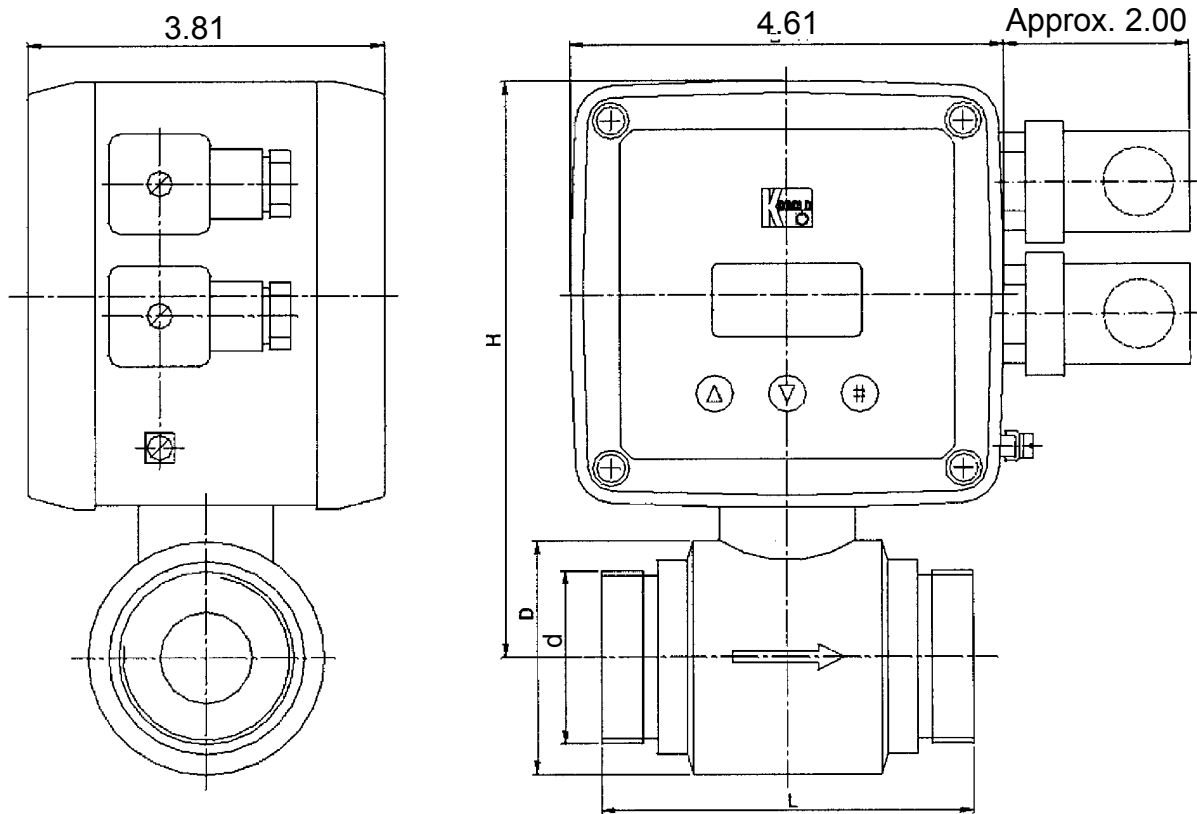

Diagram 2.1 Dimensions



Type	L	D	d	H
DMI-XX02	3.4	2.1	3/4 NPT	5.9
DMI-XX04	3.4	2.1	3/4 NPT	5.9
DMI-XX06	4.0	2.5	1-1/4 NPT	6.3
DMI-XX08	5.1	3.6	2-1/2 NPT	6.9

3.0 Mechanical Installation

3.1 Installation Requirements and Precautions

This flowmeter should be installed away from sources of strong electromagnetic fields. These sources include large electric motors, generators and transformers. The use of ferromagnetic process connectors should also be avoided as they can affect the propagation of the magnetic field generated by the flowmeter. If metal connections are required, use stainless steel, bronze or copper which are non-ferromagnetic

The flowmeter can be installed in any orientation. It is essential though, that the pipe be full. The flowmeter’s calibration assumes a full pipe. If the pipe is not full, measuring errors will result.

A **minimum** straight piping requirement of 5X the nominal flowmeter measuring tube diameter upstream and 5X the flowmeter measuring tube diameter downstream is required. These straight piping runs should have no bends, elbow, tees reducers, valves or other appurnances. The table below gives inlet and outlet piping requirements for each meter size. In all cases a reducing bushing must be installed at the flowmeter inlet and outlet to reduce from the fitting size to the required pipe diameter for the inlet and outlet straight piping runs.

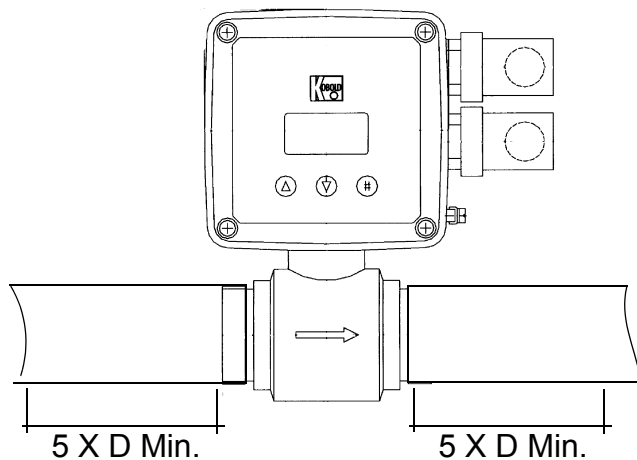
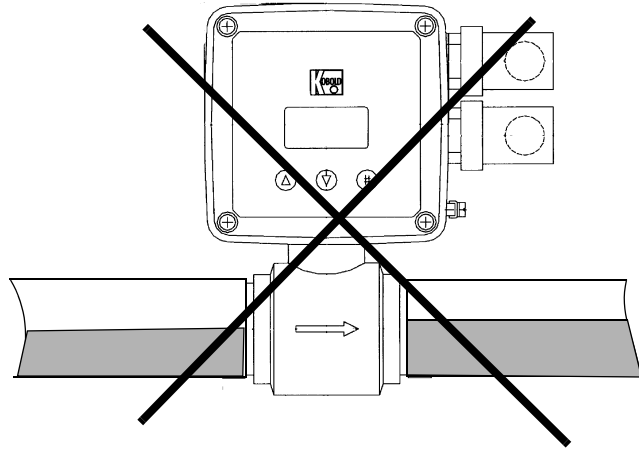
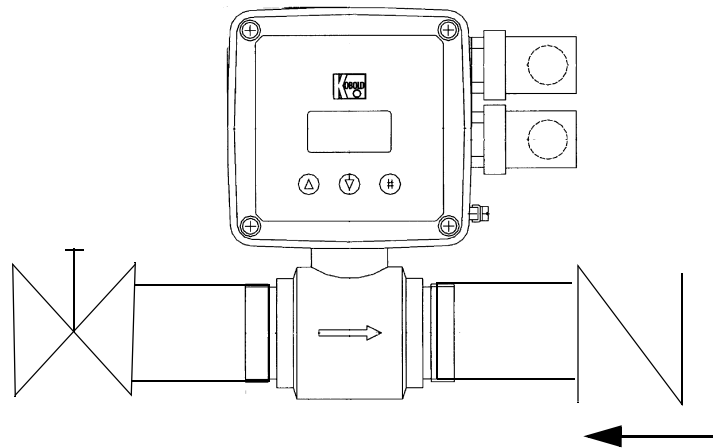

Table 3.1 Inlet and Outlet Piping Requirements

Base Model Number	Measuring Tube Diameter	Required Inlet and Outlet Pipe I.D. and Straight Run Length	Flowmeter Fitting Size	Inlet and Outlet Reducing Bushing Required
DMI-2302/DMI-2402	3/8"	3/8" I.D. X 2" minimum	3/4" NPT	3/4" to 3/8"
DMI-2304/DMI-2404	1/2"	1/2" I.D. X 2.5" minimum	3/4" NPT	3/4" to 1/2"
DMI-2306/DMI-2406	1"	1" I.D. X 5" minimum	1-1/4" NPT	1-1/4" to 1"
DMI-2308/DMI-2408	2"	2" I.D. X 10" minimum	2-1/2" NPT	2-1/2" to 2"

Valves or other shut-off devices should be installed downstream of the flowmeter in order to keep the piping filled when the system is not operating. If the piping upstream of the flowmeter drains when the system is shut down, a check valve should be installed in order to keep the flowmeter filled with liquid. These precautions will minimize the effects of water hammer when the system is started.



For installation in horizontal pipe runs, the formation of gas pockets in the pipe can cause measuring errors. Gas pocket formation can be minimized if the horizontal piping run is plumbed in at a slight up angle of 3-5 degrees.

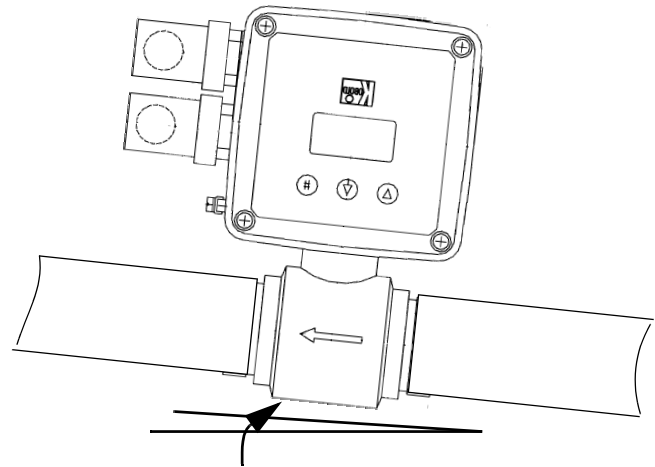

When piping into a horizontal piping run, the meter should be installed with the electronics housing either in the 12 o'clock or 6 o'clock positions. This will put the measuring electrodes in a horizontal axis and will insure that the measuring electrodes are not insulated by air pockets at the top of the pipe.

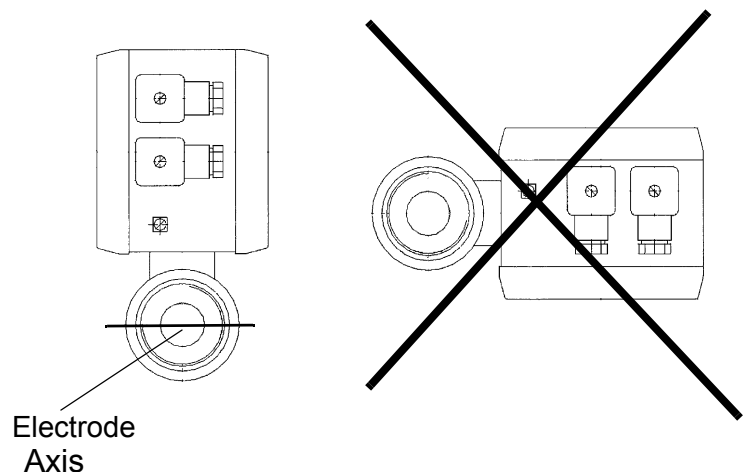

Entrained gas bubbles carried along in the pipe can cause measuring errors. To avoid this, the meter should never be installed at the high point in a system.

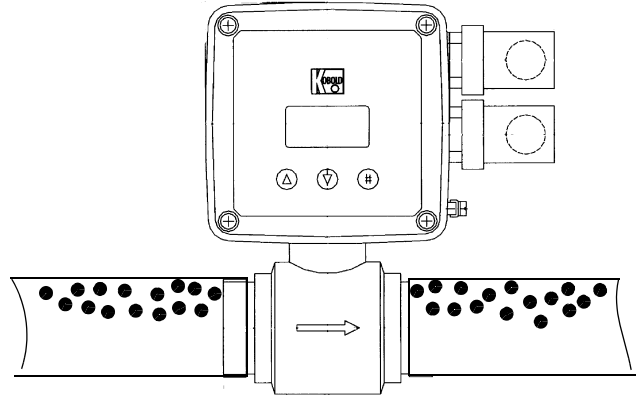

4.0 Electrical Connections

4.1 Grounding

It is imperative that the flowmeter and the liquid being measured are properly grounded and are both at the same ground potential. The best way to do this is to ensure that the grounding lug on the flowmeter case is connected to a good earth ground. This ground lug connects internally to grounding electrodes in the flow measuring tube, thereby ensuring that both the flowmeter and the liquid are grounded. There is also a ground lug on the flowmeter's power supply plug (bottom plug). It is not necessary or desirable to ground the power plug to an earth ground if the case ground lug is being used to ground the meter. See Diagram 4.1

Diagram 4.1 Grounding

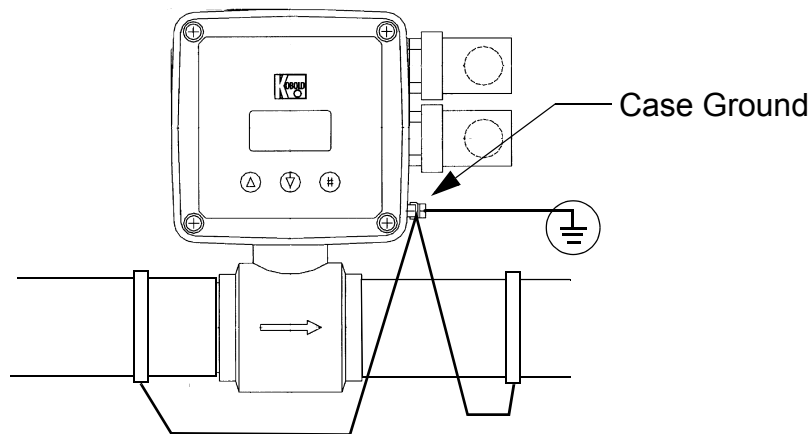

Note: For metal piping systems, connect the case ground to the inlet and outlet piping and a power system ground

Diagram 4.2 Electrical Wiring

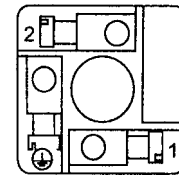
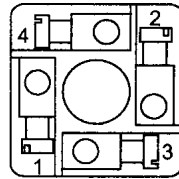
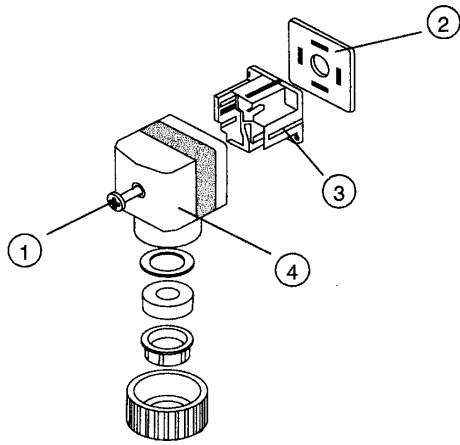

Top Plug = Signal Outputs

- 1 = 4-20 mA GND
- 2 = + 4-20 mA
- 3 = Pulse Out
- 4 = Pulse GND

Bottom Plug = Power

- 1 } = 24 VAC/VDC
- 2 } (non-polarized)
- 3 ⊕

Top Plug = Signal Outputs

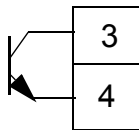

Pulse/Contact Output
NPN Open Collector
16-30VDC/200 mA Max.

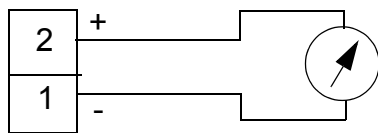

0/4-20 mA (optional)
Loop load 600 ohm Max.

5.0 Operation

5.1 Factory Default Settings

The DMI series is shipped from the factory with the following factory default settings. These settings can be changed in the field per section 5.3, Programming Steps.

Table 5.1 DMI Factory Default Settings

Flow Range	
DMI-2302/DMI-2402	50 L/Min.
DMI-2304/DMI-2404	100 L/Min.
DMI-2306/DMI-2406	300 L/Min.
DMI-2308/DMI-2408	1200 L/Min.

Table 5.1 DMI Factory Default Settings

Units	L/Min.
Current Output (option)	4-20 mA
Damping	5 Sec.
Pulse Output	1 Pulse/Liter
Pulse Width	20 mSec.

5.2 Programming General

The DMI series is fully programmable via a keypad accessible menu. During programming the meter remains functioning. The current and pulse outputs will continue to indicate the instantaneous operating flow conditions.

The functions of the individual programming keys is as follows:

- #** Toggle back and forth between the operating mode and the programming menu
- ▲** Scroll up through menu. Also used to change menu parameter values.
- ▼** Scroll down through menu. Also used to jump to the next digit when changing the menu parameter values.
- ↻** the ENTER function requires that both the ▲ and ▼ buttons are pushed simultaneously. ENTER is used to turn program protection on and off and is used to store new parameter values.

5.3 Programming Steps

5.3.1 Program Protection

The DMI series has a program protection feature which disables the ability to change the program values. The first step to take in the setup is to ensure that the program protection is turned off. This will allow the user to change the setup program parameter values. To turn off program protection, push the # button to toggle to the setup program. Then use the ▼ button to scroll to **Prog. protection**. If the status display indicates that program protection is on, press ▲ and ▼ simultaneously to turn program protection off. Then use the ▼ button to proceed through the programming menu. After programming is completed, program protection can be turned back on.

5.3.2 Language

This programming step allows the user to choose the language for the display. Press ▲ and ▼ simultaneously to enter this programming step. Then use the ▼ button to step through the language choices of English, French, Spanish and German. Press ▲ and ▼ simultaneously to select a language. Then press the ▼ button to proceed through the programming menu.

5.3.3 Size

This step is used to match the electronics with the flow tube size. **Since this is typically done at the factory, the end user would not normally have to use this programming step, except in a case where the user is replacing the electronics.** If the settings are changed in the field, erroneous readings will result. Press the ▼ button to proceed to the next programming step.

5.3.4 Range DN

Indicates the highest full scale reading that the flowmeter is capable of measuring. This step is for information only and is not a programming step. Press the ▼ button to proceed to the next programming step.

5.3.5 Range

This step sets the maximum measuring range of the flowmeter. This step also sets the maximum span of the 4-20 mA transmitter for units which have this option. Press ▲ and ▼ simultaneously to enter this programming step. Use the ▲ button to change the value of each digit. Press the ▼ button to move to the next digit. Press ▲ and ▼ simultaneously to accept a range after it has been set.

Note: If the user enters a range value which is above or below the measuring capability of the flowmeter, an error will occur. If the range entered by the user is below the measuring capability of the meter, the display will read **<0.05 DN**. If the range entered by the user is above the measuring capability of the meter the display will read **>Range DN**. In this case, press the ▲ button and repeat the step, entering the correct value.

5.3.5 Range (cont.)

The following gives the permissible values which can be entered for each flowmeter size

- For **DMI-2302 & 2402** (size DN 10/ 3/4" NPT), **Range** can be set to any value between 1 and 10 GPM
- For **DMI-2304 & 2404** (size DN 15/ 3/4" NPT), **Range** can be set to any value between 2 and 26 GPM
- For **DMI-2306 & 2406** (size DN 25/ 1-1/4" NPT), **Range** can be set to any value between 4 and 79 GPM
- For **DMI-2308 & 2408** (size DN 50/2-1/2" NPT), **Range** can be set to any value between 16 and 317 GPM

After the range has been set, press the ▼ button proceed to the next programming step.

5.3.6 Unit

This programming step selects the measuring units for the flowmeter display. Press ▲ and ▼ simultaneously to enter this programming step. use the ▼ button to toggle through the available measuring unit choices. Press ▲ and ▼ simultaneously to select a measuring unit. press the ▼ button proceed to the next programming step.

5.3.7 Damping

This programming step sets the flowmeter response time to a change in flow rate. The damping value can be set to any whole number between 5 and 40 seconds. The minimum response time is 5 seconds. Press ▲ and ▼ simultaneously to enter this programming step. Use the ▲ button to change the value of each digit. Press the ▼ button to move to the next digit. Press ▲ and t simultaneously to accept a value after it has been set.

Note: If the user enters a cutoff value which is below 5 or above 40, an error will occur. The display will read < 5 s or > 40 s. In this case press the ▲ button and repeat the step, entering a value between 5 and 40 seconds.

When a correct damping value has been entered, press the ▼ button proceed to the next programming step.

5.3.8 Low-flow cut-off

This step allows the user to input a cutoff value between 0 and 10% of full scale flow. When the actual system flow drops below this cutoff, the display and output will indicate zero flow. Press s and t simultaneously to enter this programming step. Use the ▲ button to change the value of each digit. Press the ▼ button to move to the next digit. Press ▲ and ▼ simultaneously to accept a value after it has been set.

Note: If the user enters a damping value which is below 0% or above 10%, an error will occur. The display will read < 0% or > 10%. In this case press the ▲ button and repeat the step, entering a value between 0 and 10%.

When a correct cut-off value has been entered, press the ▼ button proceed to the next programming step.

5.3.9 Prog. Output

This programming step allows the user to set the contact output to function in various modes. Press ▲ and ▼ simultaneously to enter this programming step. press the ▼ button to toggle through the selections. the description for each selection is as follows:

- Pulses:** Flowmeter will generate one pulse/gallon or one pulse/liter of flow through, depending on whether U.S. or metric measuring units were selected during setup.
- F/R Signal:** Contacts activates when flow is in the forward direction and de-activates if the flow is in the reverse direction.
- General Alarm:** Contact activates if the flowmeter is in an empty pipe condition or if the system flowrate exceeds 105% of the flowmeter's measuring capability.
- MIN Alarm:** The contact activates on a low flow condition which is below the **MIN Alarm** setpoint. The **MIN Alarm** setpoint is set by the user in a subsequent programming step.
- MAX Alarm:** The contact is activated when actual flow is below the **Max Alarm** setpoint. The contact de-activates when the flow increases above the **Max. Alarm** setpoint. The **Max Alarm** setpoint is set by the user in a subsequent programming step.
- MIN/MAX Alarm:** The contact is activated when actual flowrate is between the **MAX Alarm** and **MIN Alarm** setpoints. The contact is de-activated if flow is above the **MAX Alarm** setpoint or below the **MIN Alarm** setpoint. The **MAX Alarm** setpoint and **MIN Alarm** setpoint are set by the user in a subsequent programming step.
- No Function:** Disables the contact.

After the desired mode has been selected, Press ▲ and ▼ simultaneously to accept the setting. Press the ▼ button proceed to the next programming step.

5.3.10 Max Alarm:

This programming step allows the user to set a **Max Alarm** setpoint. The setpoint value can be set to any whole number between 0 to 105%. Press ▲ and ▼ simultaneously to enter this programming step. Use the ▲ button to change the value of each digit. Press the t button to move to the next digit. Press ▲ and ▼ simultaneously to accept a value after it has been set.

Note: If the user enters a **MAX Alarm** setpoint which is above 105% or below 0%, an error will occur. The display will read **Out of Range**. In this case press the ▲ button and repeat the step, entering a value between 0% and 105%.

An alarm will always be indicated on the display, but in order to achieve contact activation, the **MAX Alarm** mode must be selected in the **Prog. Output** Programming step.

When a correct **MAX Alarm** value has been entered, press the ▼ button proceed to the next programming step.

5.3.11 **MIN Alarm**

This programming step allows the user to set a **Min Alarm** setpoint. The setpoint value can be set to any whole number between 0 to 105%. Press ▲ and ▼ simultaneously to enter this programming step. Use the ▲ button to change the value of each digit. Press the ▼ button to move to the next digit. Press ▲ and ▼ simultaneously to accept a value after it has been set.

Note: If the user enters a **MIN Alarm** setpoint which is above 105% or below 0%, an error will occur. The display will read **Out of Range**. In this case press the ▲ button and repeat the step, entering a value between 0% and 105%.

An alarm will always be indicated on the display, but in order to achieve contact activation, the **Min Alarm** mode must be selected in the **Prog. Output** Programming step.

When a correct **MIN Alarm** value has been entered, press the ▼ button proceed to the next programming step.

5.3.12 **Current Output**

For meters which have the optional current output, This programming step allows the user to select a 0-20 mA or 4-20 mA output. Press ▲ and ▼ simultaneously to enter this programming step. press the ▼ button to toggle through the selections. Press ▲ and ▼ simultaneously to accept a selection. When the proper selection has been accepted, press the ▼ button proceed to the next programming step.

5.3.13 **lout at alarm**

For meters which have the optional current output, this programming step allows the user to select the current output value which will occur during an alarm condition. The choices are 0 mA, 3.6 mA or 21 mA for a 4-20 mA transmitter and 0 mA or 21 mA for a 0-20mA transmitter. Press ▲ and ▼ simultaneously to enter this programming step. press the ▼ button to toggle through the selections. Press ▲ and ▼ simultaneously to accept a selection. When the proper selection has been accepted, press the ▼ button proceed to the next programming step.

5.3.14 **Totalizer Reset**

This programming step allows the user to reset the totalizer display. Press ▲ and ▼ simultaneously to enter this programming step. The display will read **Yes -> Enter**. Press ▲ and ▼ simultaneously to reset the totalizer or press the ▼ button to cancel the reset. Press the ▼ button proceed to the next programming step.

5.3.15 System zero Adj.

The DMI series is zeroed at the factory with water prior to shipping. If the meter is to be used with water, no re-zeroing is required. If the meter will be used with a media other than water, the unit may be zeroed in the field to obtain more accurate results. There is a choice between manual and automatic zero for this menu item. The automatic zero would typically be used in the field. the manual zero is used for initial zeroing at the factory. In order to perform a proper zero, the pipe must be completely full of liquid and in an absolute no flow condition. Press ▲ and ▼ simultaneously to enter this programming step. The display will read **manual?**, press the ▼ button to toggle to **automatic?** Press ▲ and ▼ simultaneously to perform the automatic zero. While the unit is zeroing the display will read * **adjust** *. When the zeroing is complete the display will read a value between 0 and 50 Hz. press the ▼ button proceed to the next programming step.

5.3.16 Display

This programming step allows the user to select a display in flow units or percent (%) of rated full scale flow. Press ▲ and ▼ simultaneously to enter this programming step. press the ▼ button to toggle through the selections of [Unit] to have the display indicate flow units or [%] to have the display read out in% of full scale. Press ▲ and ▼ simultaneously to accept a selection. When the proper selection has been accepted, press the ▼ button proceed to the next programming step.

5.3.17 Contrast

This programming step allows the user to adjust the display contrast. Press ▲ and ▼ simultaneously to enter this programming step. Use the ▲ or ▼ button to adjust contrast up or down. Press ▲ and ▼ simultaneously to accept the adjustment. Press the ▼ button proceed to the next programming step.

5.3.18 Simulation

This programming step allows the user to simulate a flow signal to test the 20 mA current loop and contact output. Press ▲ and ▼ simultaneously to enter this programming step. Press the ▼ button to toggle simulation from **off** to **on**. Press ▲ and ▼ simultaneously again to confirm. The display will then indicate a value of 0%. The user must now enter an initial simulated flow value in% of full scale. The value can be any whole number between 0 and 100% of full scale. Use the ▲ button to change the value of each digit. Press the ▼ button to move to the next digit. Press ▲ and ▼ simultaneously to accept a value after it has been set.

Note: If a simulation flow value of greater than 100% is entered, an error will occur and a message, **Out of range** will be displayed. If this occurs press the ▼ button to exit the step and ▲ and ▼ simultaneously to start over.

After the initial flow value has been set, press the # button to return to the display mode. A flowrate value which corresponds to the simulated% of full scale flow is displayed. The user can now press and release the ▲ or ▼ button to change this simulated value. The current transmitter and contact output will respond accordingly.

To exit the simulation mode, press the # button to toggle back to **Simulation** in the programming menu. Press ▲ and ▼ simultaneously to enter this programming step. Press the ▼ button to toggle simulation from **on** to **off**. Press ▲ and ▼ simultaneously to accept this setting. Press the ▼ button proceed to the next programming step.

5.3.19 DL5000 1/2000

This step is for information only and displays the software version which is resident on the flowmeter electronics. Press the ▼ button proceed to the next programming step.

5.3.20 Code

For KOBOLD service only not programmable by the user

Note: This is the end of the programming menu. To deter tampering with the settings, Press the ▼ button to toggle back to **program protection**. be sure to turn program protection back on (see step 5.3.1).

6.0 Maintenance

The DMI series is an electronic flow measuring device with no moving parts. It is therefore virtually maintenance free. If a coating media is run through the meter, an occasional cleaning of the flow tube may be required if the coating electrically insulates the electrodes. This would be evidenced by a decrease or loss of output signal.

CAUTION

PLEASE READ THE FOLLOWING WARNINGS BEFORE ATTEMPTING
INSTALLATION OF YOUR NEW DEVICE. FAILURE TO HEED THE
INFORMATION HEREIN MAY RESULT IN EQUIPMENT FAILURE AND
POSSIBLE SUBSEQUENT PERSONAL INJURY.

- **User's Responsibility for Safety:** KOBOLD manufactures a wide range of process sensors and technologies. While each of these technologies are designed to operate in a wide variety of applications, it is the user's responsibility to select a technology that is appropriate for the application, to install it per these installation instructions, to perform tests of the installed system, and to maintain all components. The failure to do so could result in property damage or serious injury.
- **Proper Installation and Handling:** Use a proper sealant with all installations. Never overtighten the unit within the fittings. **Never use the housing to thread the unit into its fitting.** Always use only an appropriate sized wrench to install the unit. Always check for leaks prior to system start-up.
- **Wiring and Electrical:** Depending on the model, a supply voltage of 24 VAC/VDC +10%/-20%. The sensor systems should never exceed this rating. Electrical wiring of the sensor should be performed in accordance with all applicable national, state, and local codes.
- **Temperature and Pressure:** The DMI series is designed to operate within the pressure/temperature limits specified in Section 2.0, Specifications. Operation outside these limitations will cause damage to the unit and possible personal injury.
- **Material Compatibility:** Check your model number with the wetted materials specification in Section 2.0, Specifications, on page 1 of this manual. Make sure that the model which you have selected is chemically compatible with the application liquids. While the meter electronics housing is liquid resistant when installed properly, it is not designed to be immersed. It should be mounted in such a way that it does not normally come into contact with fluid.
- **Flammable, Explosive and Hazardous Applications:** The DMI series is not an explosion proof or intrinsically safe design. It should not be installed in hazardous atmospheres which require an explosion proof or intrinsically safe system.
- **Make a Fail-safe System:** Design a fail-safe system that accommodates the possibility of switch or power failure as well as operator error. In critical applications, KOBOLD recommends the use of redundant backup systems and alarms in addition to the primary system.